

OPTIONAL POSITION (3)

PUMP SIZE	U	KEYWAY	
		LENGTH	SQ.
1-1/2 x 3 x 10	1-1/8	1-3/4	1/4
2 x 4 x 10	1-3/8		3/8

DISCH.	SUCT.	CASE BORE	D	DC	DH	L	M	Y	Z
1-1/2	3	10	8	7	14-1/2	12-1/4	5-3/4	5-13/16	6-1/8
2	4	10	9	7-5/8	15-11/16	13-7/16	6-3/4	6-9/16	6-9/16

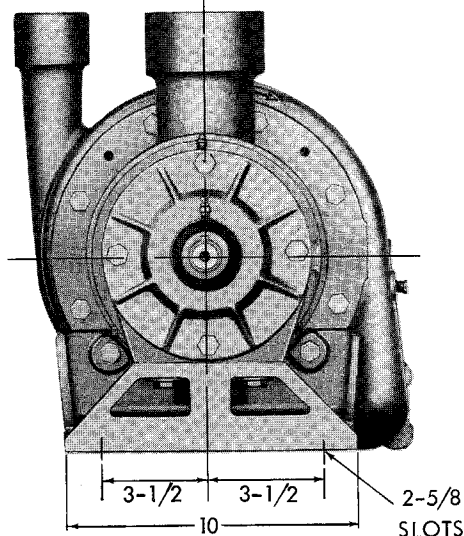

VIEW AA

NOTES

1. ALL DIMENSIONS IN INCHES.
2. DIMENSIONS MAY VARY $\pm 1/4$.
3. NOT FOR CONSTRUCTION PURPOSES UNLESS CERTIFIED.

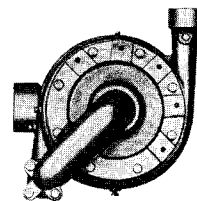

STANDARD POSITION 1

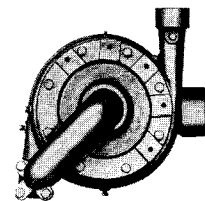

POSITION 2

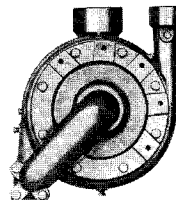

POSITION 3

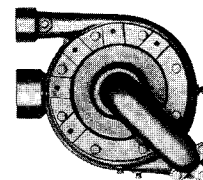

POSITION 4

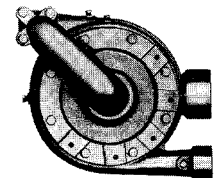

POSITION 5

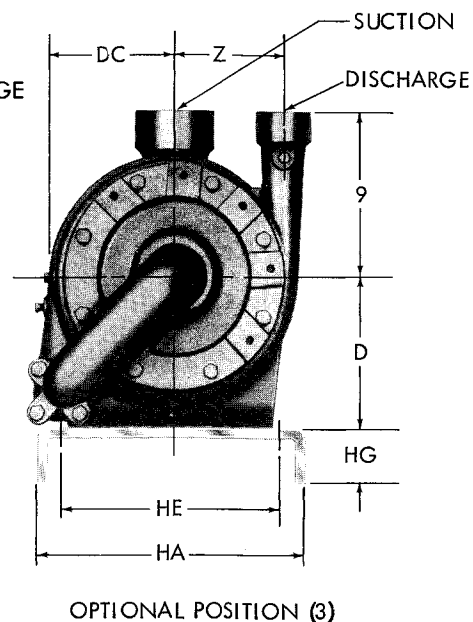
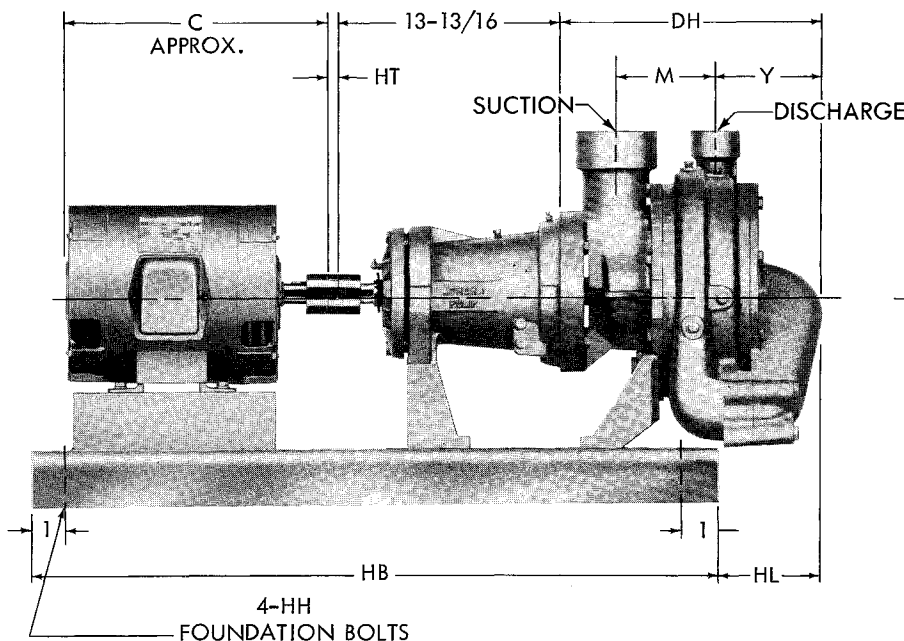

MOTOR	C	BASE NO.	HB	HT	HG	HE	HA	HH
143T	12	1	34 3/4	3	9	12	1/2	
145T	13	1	34 3/4	3	9	12	1/2	
182T	13	2	38 3/4	3	9	12	1/2	
184T	14	2	38 3/4	3	9	12	1/2	
213T	16	2	38 3/4	3	9	12	1/2	
215T	18	3	42 7/8	4	10	13	5/8	
254T	21	3	42 7/8	4	10	13	5/8	
256T	23	4	52 7/8	4-1/8	12	15	5/8	
284TS	22	4	52 7/8	4-1/8	12	15	5/8	
286TS	24	4	52 1	4-1/8	12	15	5/8	
324TS	25	5	48 1	4	15	18	5/8	
326TS	26	5	48 1	4	15	18	5/8	
364TS	27	5	48 1	4	15	18	5/8	
365TS	28	6	54 1/4	4	15	18	5/8	

NOTES

1. ALL DIMENSIONS IN INCHES.
2. DIMENSIONS MAY VARY $\pm 1/4$.
3. NOT FOR CONSTRUCTION PURPOSES UNLESS CERTIFIED.
4. CONDUIT BOX IS SHOWN IN APPROXIMATE LOCATION. DIMENSIONS ARE NOT SPECIFIED AS THEY VARY WITH EACH MOTOR MANUFACTURER.

DISCH.	SUCT.	CASE BORE	D	DC	DH	HL	M	Y	Z	FRAME	143T	145T	182T	184T	213T	215T	254T	256T	284TS	286TS	324TS	326TS	364TS	365TS
										C	11	12	13	14	16	18	21	23	22	24	25	26	27	28
1-1/2	3	10	8	7	14-1/2	8	5-3/4	5-13/16	6-1/8	BASE	1	1	2	2	2	3	3	4	4	4	5	5		
2	4	10	9	7-5/8	15-11/16	9-3/16	6-3/4	6-9/16	6-9/16	BASE			2	2	2	3	3	4	4	4	5	5	5	6

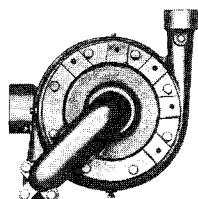

STANDARD POSITION 1

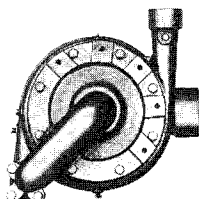

POSITION 2

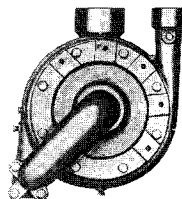

POSITION 3

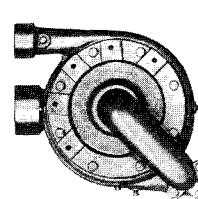

POSITION 4

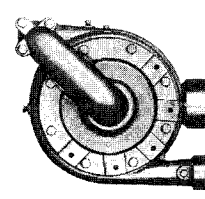

POSITION 5

AURORA MODEL _____ PUMPS ON STEEL DRIP RIM BASES

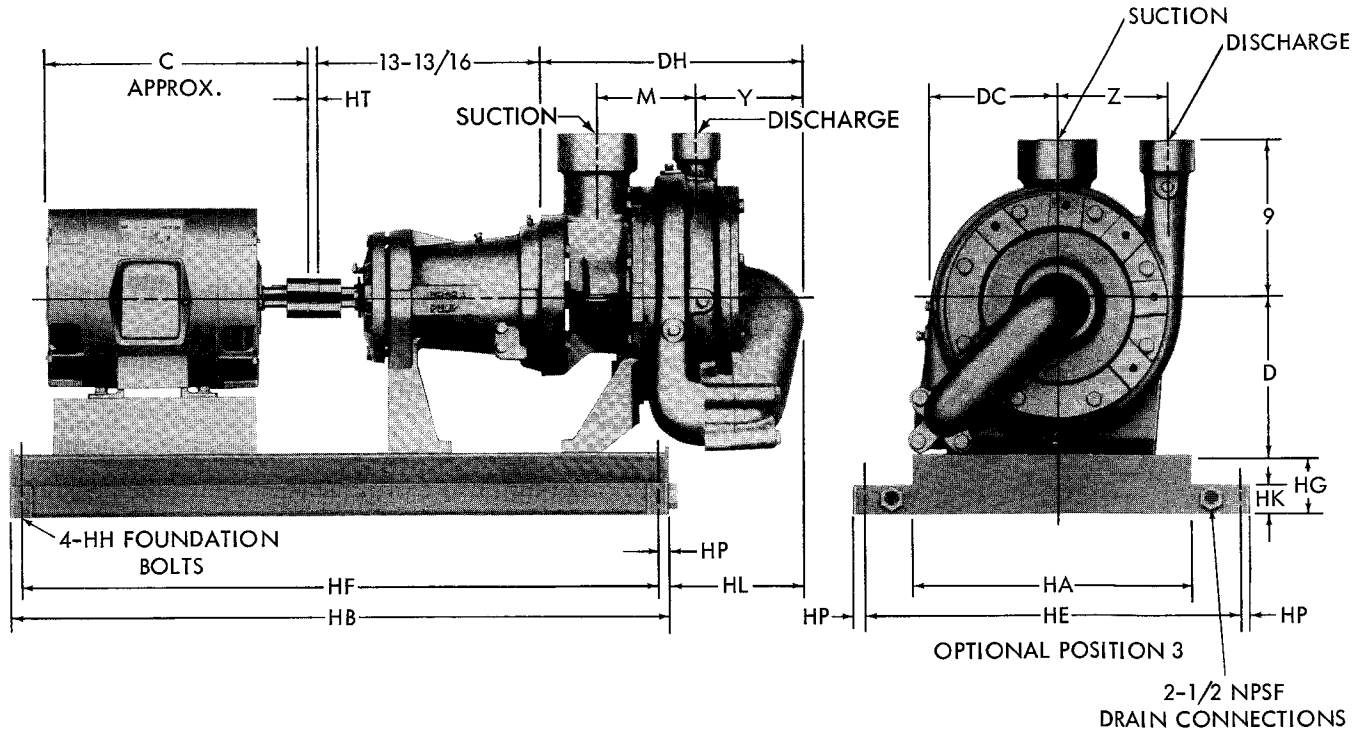

MOTOR	C	BASE NO.	HB	HT	HG	HE	HA	HH	HK	HF	HP
143T	12	5	36-1/2	3/4	3	15-7/8	11	1/2	1-1/2	35-1/8	11/16
145T	13	5	36-1/2	3/4	3	15-7/8	11	1/2	1-1/2	35-1/8	11/16
182T	13	5	36-1/2	3/4	3	15-7/8	11	1/2	1-1/2	35-1/8	11/16
184T	14	5	36-1/2	3/4	3	15-7/8	11	1/2	1-1/2	35-1/8	11/16
213T	16	5	36-1/2	3/4	3	15-7/8	11	1/2	1-1/2	35-1/8	11/16
215T	18	6	42-1/2	7/8	3	15-7/8	11	1/2	1-1/2	41-1/8	11/16
254T	21	8	42-1/2	7/8	3	19	14	5/8	1-1/2	41	3/4
256T	23	9	48-1/2	7/8	3	19	14	5/8	1-1/2	47	3/4
284TS	22	9	48-1/2	7/8	3	19	14	5/8	1-1/2	47	3/4
286TS	24	9	48-1/2	1	3	19	14	5/8	1-1/2	47	3/4
324TS	25	11	46-1/2	1	4	25-1/8	18	3/4	2	44-7/8	13/16
326TS	26	11	46-1/2	1	4	25-1/8	18	3/4	2	44-7/8	13/16
364TS	27	11	46-1/2	1	4	25-1/8	18	3/4	2	44-7/8	13/16
365TS	28	12	54-1/2	1/4	4	25-1/8	18	3/4	2	52-7/8	13/16

NOTES

1. ALL DIMENSIONS IN INCHES.
2. DIMENSIONS MAY VARY ± 1/4.
3. NOT FOR CONSTRUCTION PURPOSES UNLESS CERTIFIED.
4. CONDUIT BOX SHOWN IN APPROXIMATE LOCATION. DIMENSIONS ARE NOT SPECIFIED AS THEY VARY WITH EACH MOTOR MANUFACTURER.

DISCH.	SUCT.	CASE BORE	D	DC	DH	HL	M	Y	Z	FRAME	143T	145T	182T	184T	213T	215T	254T	256T	284TS	286TS	324TS	326TS	364TS	365TS
										C	11	12	13	14	16	18	21	23	22	24	25	26	27	28
1-1/2	3	10	8	7	14-1/2	8	5-3/4	5-13/16	6-1/8	BASE	5	5	5	5	5	6	8	9	9	9	11	11		
2	4	10	9	7-5/8	15-11/16	9-3/16	6-3/4	6-9/16	6-9/16	BASE			5	5	5	6	8	9	9	9	11	11	11	12

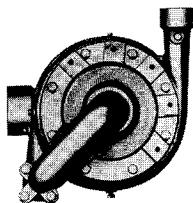

STANDARD POSITION 1

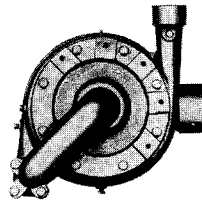

POSITION 2

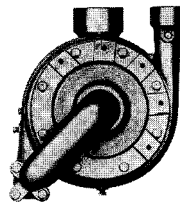

POSITION 3

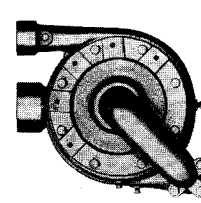

POSITION 4

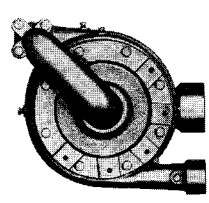

POSITION 5