

410 Series Single-Stage Split Case Pumps

- Capacities To 15000 GPM
- Heads To 663 Feet
- Temperatures To 275° F

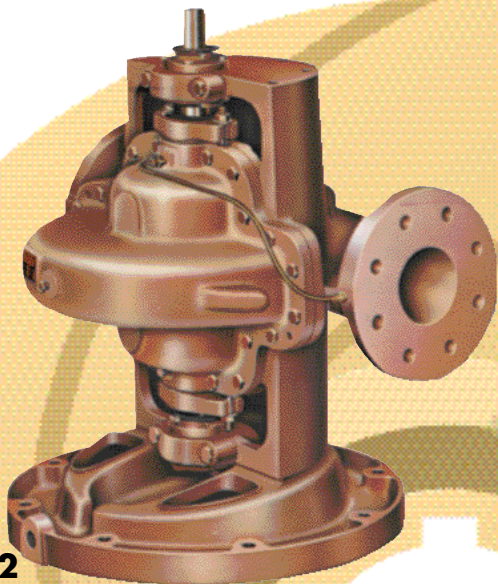

MODEL 412

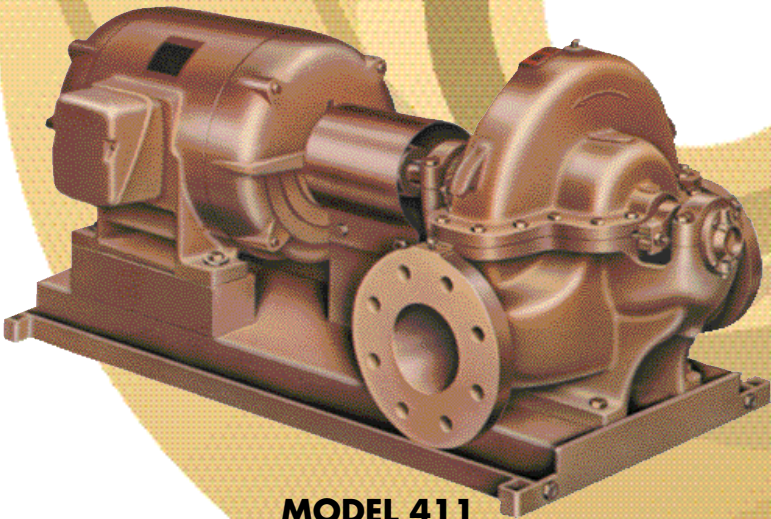

MODEL 411

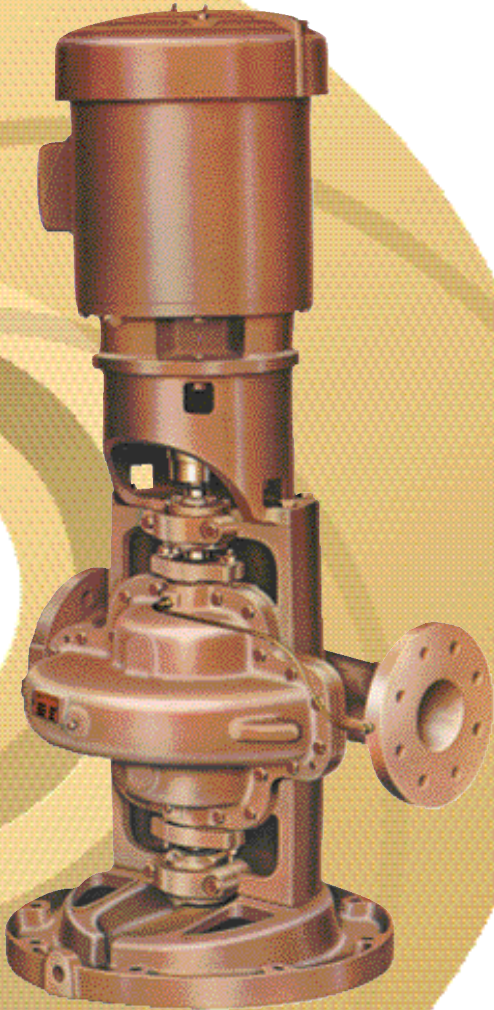

MODEL 413

Introduction 410 Series Pumps

The horizontal split case pump has long and properly been used for the handling of liquids where the utmost in reliability and accessibility are paramount. Billions of gallons of liquid have been pumped by split case double suction pumps and billions more will be pumped considering the

rapid industrial, agricultural and commercial expansion. The Aurora 410 Series pumps make a significant contribution to the customer requirements for pumps on this type of service. The 410 Series is a modern design based on Aurora Pump's over 85 years of experience with the design,

sales and manufacturing of split case pumps. Look through this bulletin and see what real accomplishments can be made when an imaginative approach is taken to the customer's problem of moving liquids within a piping system.

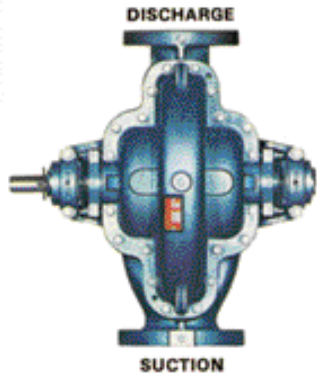

**STANDARD
RIGHT HAND ROTATION**

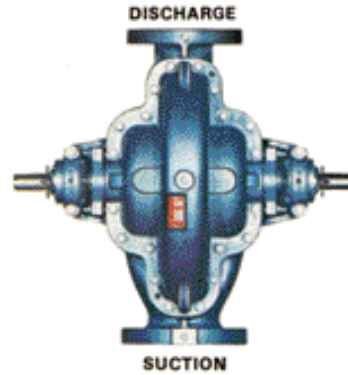

**OPTIONAL DUAL DRIVE
RIGHT HAND ROTATION**



**OPTIONAL
LEFT HAND ROTATION**

QUICK REFERENCE 410 SERIES FEATURE SELECTOR

STANDARD

- Bronze fitted pump construction
- Bronze shaft sleeves
- Dynamically balanced impellers
- Bronze case wearing rings
- Twin volute on 10" and larger pumps
- Stainless steel impeller key
- Regreasable ball bearings
- Single row ball bearing (inboard)
- Double row ball bearing (outboard)
- Mechanical seals...single unbalanced (Model 412 and 413)
- Graphite and TFE lubricated acrylic packing
- Internal bypass between casing and stuffing box
- 125# ASA flanges
- 250 psi case working pressure
- Carbon steel shaft
- Stuffing box bushings
- Lifting lugs
- Hydrostatic test
- Cast integral bearing arms
- Water slingers and grease seals
- External bypass between casing and stuffing box (Model 412 and 413)
- Coupling guard (Model 411)

OPTIONAL

- All iron, all bronze or special alloy pump construction
- Hardened 440C stainless steel shaft sleeves (packing only)
- 316 stainless steel shaft sleeves (mechanical seal)
- Impeller wearing rings
- Oil lubricated ball bearings (Model 411 horizontal pump)
- Mechanical seals...single unbalanced (Model 411) ...single balanced (All Models)
- Stainless steel or monel shaft
- External bypass between casing and stuffing box (Model 411)
- Steel drip rim, formed steel or fabricated steel bases
- Double extended shaft (Model 411)
- Right or left hand rotation
- Certified performance test
- Packing with lantern ring (Model 411)
- 250# ASA suction and discharge flanges
- Bottom suction or chairmounted pumps
- Water cooled cartridge caps

Specifications and Dimensions

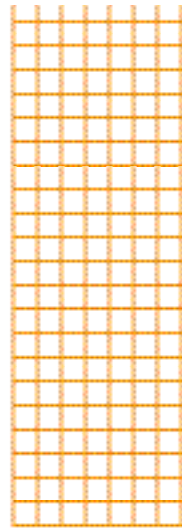

PUMP SIZE			P-SERIES	PUMP WT (LBS)		A	D**	S	X	CP	HY	VE	YY
DISCH	SUCT	BORE		411	413								
2	2-1/2	9	1	145	215	18	7	3-1/2	8-1/2	21	4-1/2	11-1/8	9
2	2-1/2	10	1	145	215	18	7	3-1/2	8-1/2	21	4-1/2	11-1/8	9
2	2-1/2	12	1	175	260	18	8	4	10	21	4-1/2	11-1/8	10-3/4
2-1/2	3	10	2	215	300	18	8	4	9-3/4	24	5-1/2	13	10
2-1/2	3	12	2	255	360	18	9	4-1/2	11	24	5-1/2	13	11-1/2
3	4	10	2	260	365	18	9	4-1/2	10	24	5-1/2	13	11
3	4	14	2	310	435	18	10	5	12	24	5-1/2	13	13
4	5	10	2	330	465	18	9	4-5/8	10	24	5-1/2	13	11-1/4
4	5	11	3	390	435	22	10	5	11-1/4	26	6-1/2	14	12-3/4
4	5	15	3	415	490	22	11	5-1/2	13	26	6-1/2	14	14
4	6	18	4	560	780	22	12-1/2	6-1/4	14	29	6-1/2	15	16
5	6	11	4	455	580	22	11	5-1/2	11-1/4	29	6-1/2	15	13-1/4
5	6	15	4	530	735	22	12-1/2	6-1/4	13-1/4	29	6-1/2	15	15
5	6	17	4	635	855	22	12-1/2	6-1/4	14	29	6-1/2	15	15
6	8	11	4	520	650	22	12-1/2	6-1/4	11-3/4	29	6-1/2	15	14-1/2
8	8	11	4	605	835	22	12-1/2	6-1/4	12	29	6-1/2	15	14-1/2
6	8	11HH	4A	990	1095	22	13-13/16	8-5/8	10	32-3/4	8-1/2	17-1/8	15
6	8	14HH	5A	1190	1410	30	13-13/16	7-1/2	15	36-3/4	8-1/2	19-7/16	17
6	8	15	5	585	735	30	13-1/2	6-3/4	14-1/4	32	7-1/2	17	16-3/4
6	8	18	5	800	1020	30	14-3/4	8	16	32	7-1/2	17	18
6	8	20	5	875	925	30	14-3/4	8	15-3/4	32	7-1/2	17	18
8	10	12	5	740	1040	30	14-3/4	8*	17	32	7-1/2	17	17-3/4
8	10	15	5	835	1085	30	14-3/4	8*	17	32	7-1/2	17	17-3/4
8	10	17	5	865	††	††	14-3/4	8	17	32	7-1/2	17	17-3/4
8	10	21	6B	955	1575	40	18-1/2	9-1/2	18	38	11-1/2	-	21
10	12	12	6B	1325	††	††	23	12	16	38	11-1/2	-	19
10	12	15	6B	1390	††	††	25	13-1/2	17	38	11-1/2	-	20
10	12	18	6B	1725	††	††	25	13-1/2	18	38	11-1/2	-	22
10	12	18D	7A	1920	††	††	25	12-1/4	20	42-15/16	11-1/2	-	24
12	14	15	7	2000	††	††	24	15	17	44	11-1/2	-	22
12	14	18	7	2100	††	††	24	15	18	44	-	-	23
14	16	18	7	2850	††	††	29-1/4	16	22	44	-	-	27

MODEL 412 & 413

POWER SERIES		1	2	3	4	5
DH	UP TO 256 HP	26	30	33	35	-
	284 HPH & UP	28	32	35	37	41
CP		23	27	29	31	35

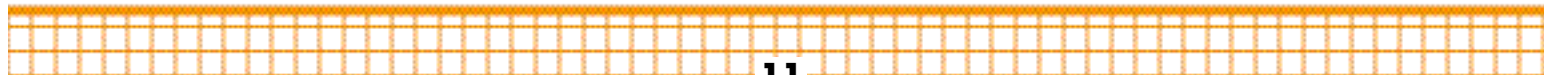
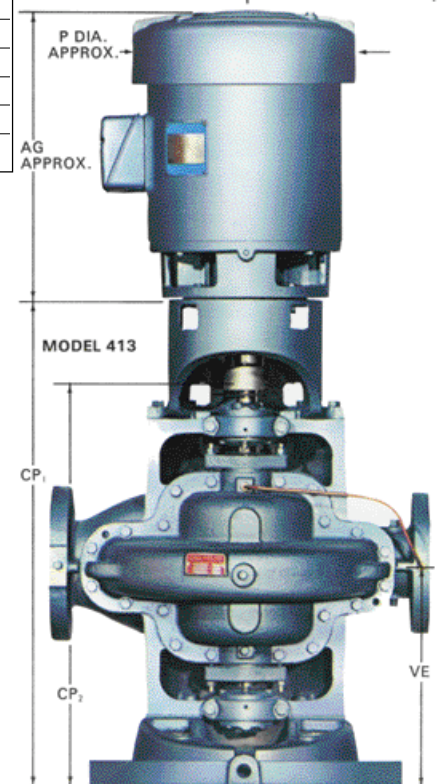
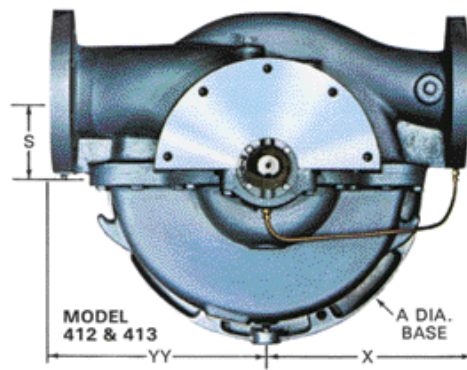
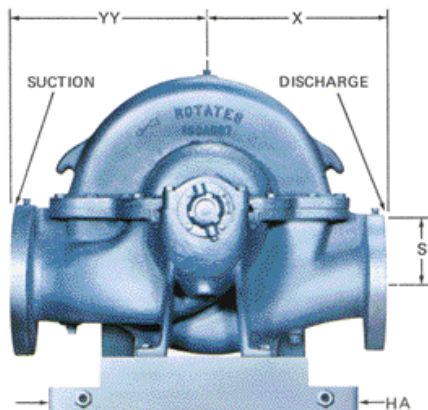

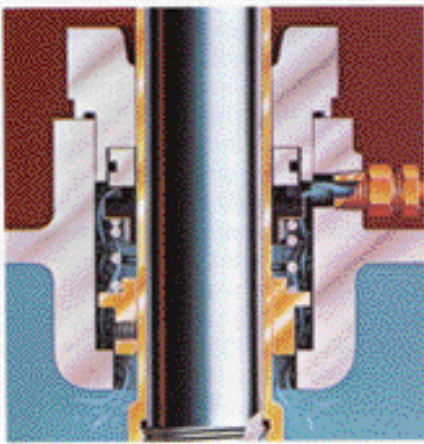

EXTERNAL UPPER SEAL FLUSH

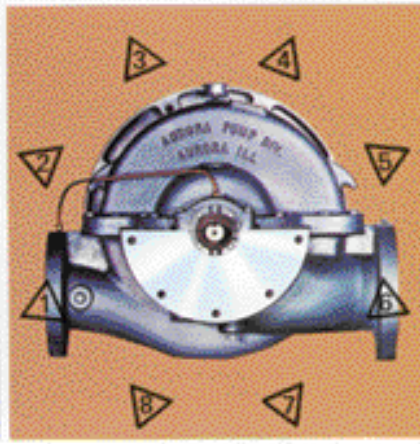

INLINE PIPING IN ANY DIRECTION

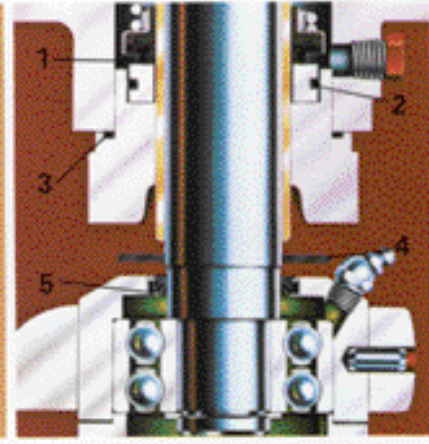

FIVE WAY BEARING PROTECTION

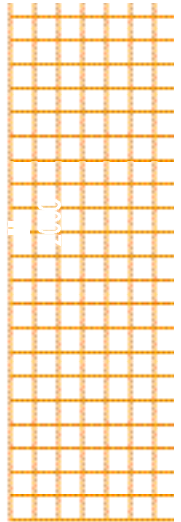

GO VERTICAL AND PUT 2 PUMPS WHERE ONLY ONE HORIZONTAL WOULD FIT.

Aurora's space saving vertical split case pumps have long been recognized for their reliability. This reputation in the field of vertical installations has been re-emphasized since the introduction of the Model 413 as pumps of unmatched quality.

VERTICAL PUMPS PROVIDE DISTINCT ADVANTAGES OVER HORIZONTAL PUMP CONSTRUCTION.

- A. Less floor space required.
- B. Inline piping arrangement allows

pipng in any direction.
 C. Elevated motor protects against potential flooding if the pump station is in a low area. Additional features described for the horizontal pumps are also found in the vertical pumps. In addition, there are several features unique only to Model 413.

- 1. COUPLING ALIGNMENT True alignment is vital to long life and proper performance. To maintain proper coupling alignment the mounting bracket is rabbet fitted to the motor.
- 2. MECHANICAL SEALS Standard construction includes carbon against

Ni-Resist face for optimum hot water performance. Long life is also assured with 303 stainless steel metal parts and "Buna-N" elastomers.

3. BEARING PROTECTION Grease seals and water slingers are provided to protect the bearings from contamination. This important feature is also standard on horizontal pumps.

4. CAST IRON DRIP RIM BASE Accurate positioning of the pump is assured by the mounting base. A drip rim is incorporated in the base design to control condensation and leakage.

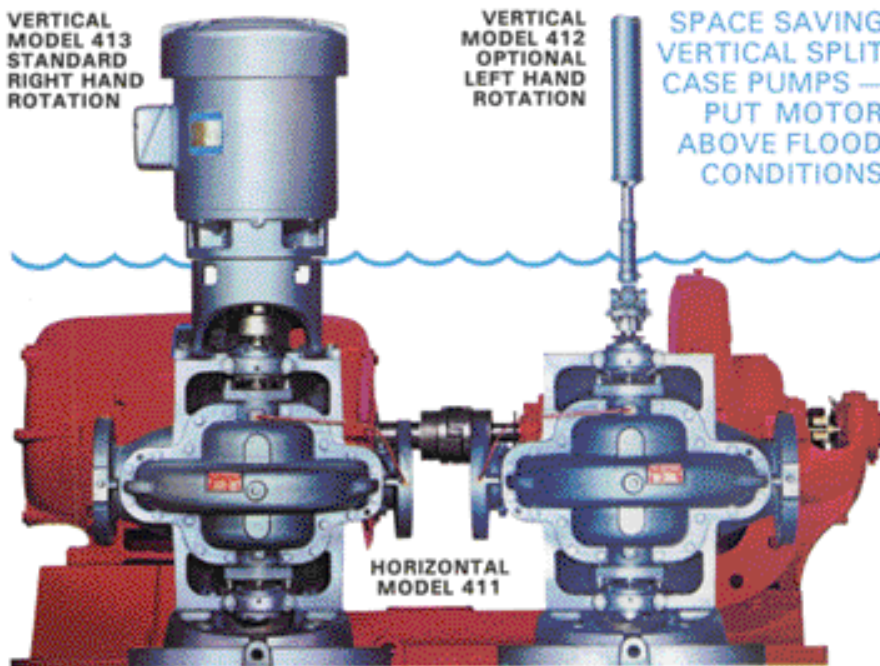

VERTICAL MODEL 413 STANDARD RIGHT HAND ROTATION

VERTICAL MODEL 412 OPTIONAL LEFT HAND ROTATION

SPACE SAVING VERTICAL SPLIT CASE PUMPS — PUT MOTOR ABOVE FLOOD CONDITIONS

HORIZONTAL MODEL 411

MODELS 411 are horizontally baseplate mounted with a driver flexibly coupled to the pump. This design is recommended where floor space is readily available and where flooding of the installation is not possible.

MODELS 412 are vertically mounted and utilize flexible shafting between the driver and the pump. This model is frequently used on difficult applications where flooding of the installation is a possibility.

MODELS 413 are vertically mounted with an elevated driver coupled directly to the pump thru a flexible coupling. Model 413 is very popular for installations where available floor space is limited and where possible flooding is marginal.



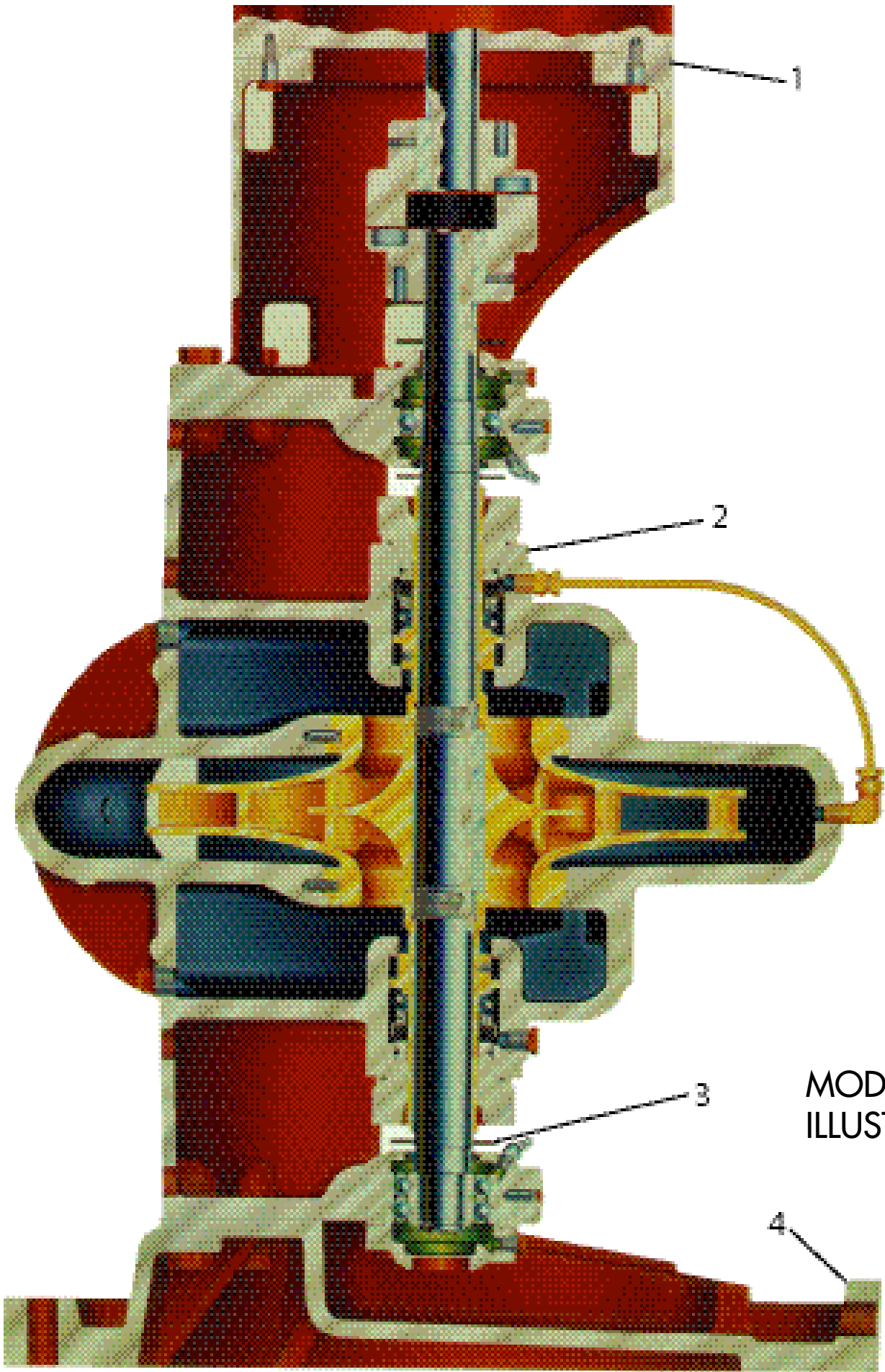

MODEL 413
ILLUSTRATED

1750 RPM

INDIVIDUAL PERFORMANCE CURVES SHOULD BE CHECKED FOR FINAL SELECTION. FOR SELECTIONS NOT SHOWN ON THIS CHART, PLEASE REFER TO FACTORY.

- POWER SERIES HQ. 1
- POWER SERIES HQ. 2
- POWER SERIES HQ. 3
- POWER SERIES HQ. 4
- POWER SERIES HQ. 4A
- POWER SERIES HQ. 5
- POWER SERIES HQ. 5A
- POWER SERIES HQ. 6B
- POWER SERIES HQ. 7
- POWER SERIES HQ. 7A

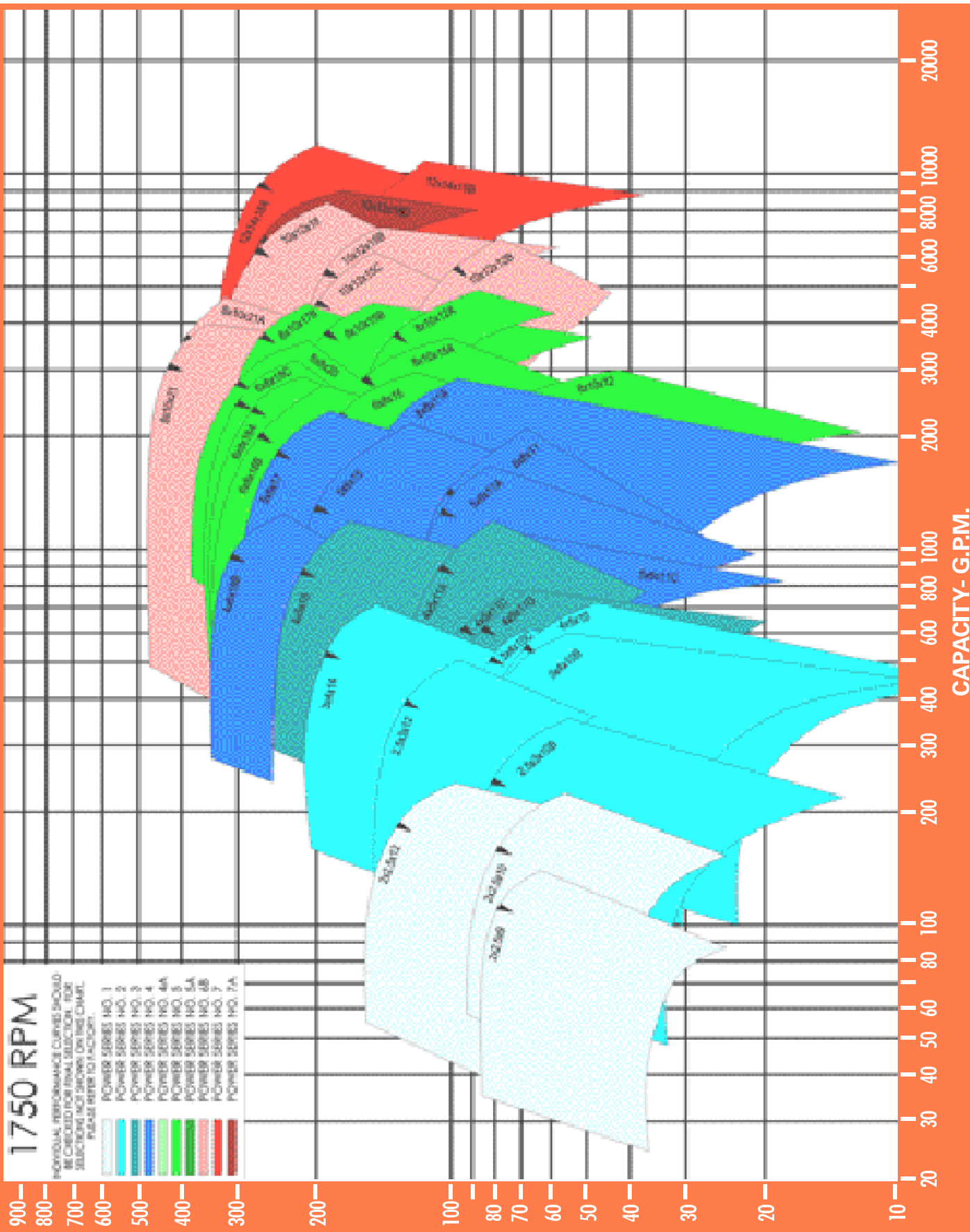

CAPACITY - G.P.M.

1150 RPM

INDIVIDUAL PERFORMANCE CURVES SHOULD BE CHECKED FOR FINAL SELECTION. FOR SELECTIONS NOT SHOWN ON THIS CHART, PLEASE REFER TO FACTORY.

- Power Series No. 1
- Power Series No. 2
- Power Series No. 3
- Power Series No. 4
- Power Series No. 4A
- Power Series No. 8
- Power Series No. 5A
- Power Series No. 6B
- Power Series No. 7A

TOTAL DYNAMIC HEAD - FEET

CAPACITY - G.P.M.

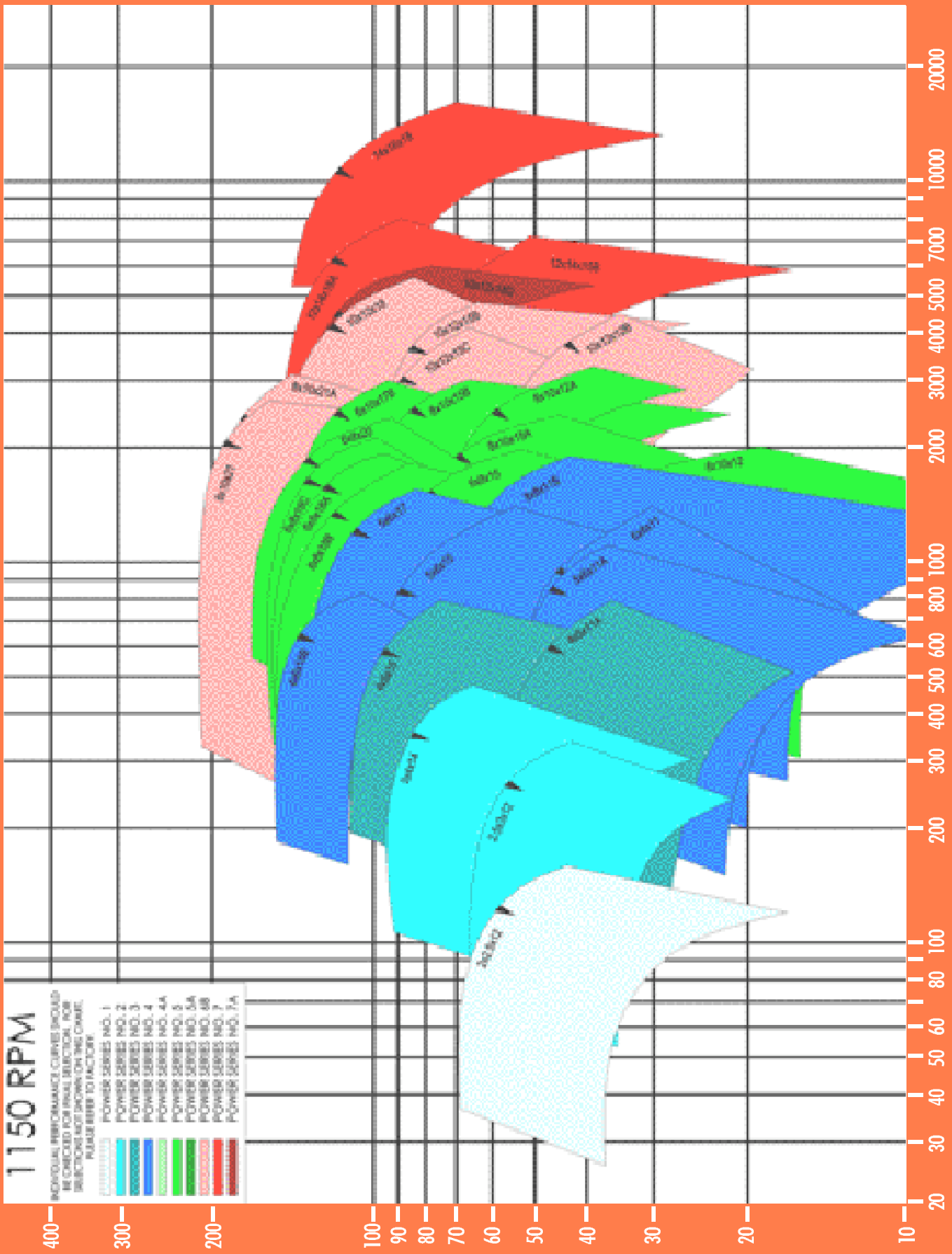

Some of the important features of the Aurora 410 Series Split Case Pumps are outlined below:

1. **SPLIT CASE DESIGN** simplifies disassembly. The suction and discharge piping and alignment is not disturbed. Simply remove the upper casing for service or inspection. Cast lifting lugs are provided. Computer-machined major components with 360 degree registered fits assure concentricity of all parts. Twin volute design balances out radial hydraulic thrust loads on larger split case pumps (see Range Charts).

2. **DYNAMICALLY BALANCED IMPELLER** is keyed to the shaft and secured by adjustable shaft sleeves. Double suction design balances out hydraulic thrust loads. Vacuum cast process and proven design provides high efficiency and performance.

3. **CASE WEARING RINGS** and throttle bushings prevent wear on the pump casing and are easily and inexpensively replaced.

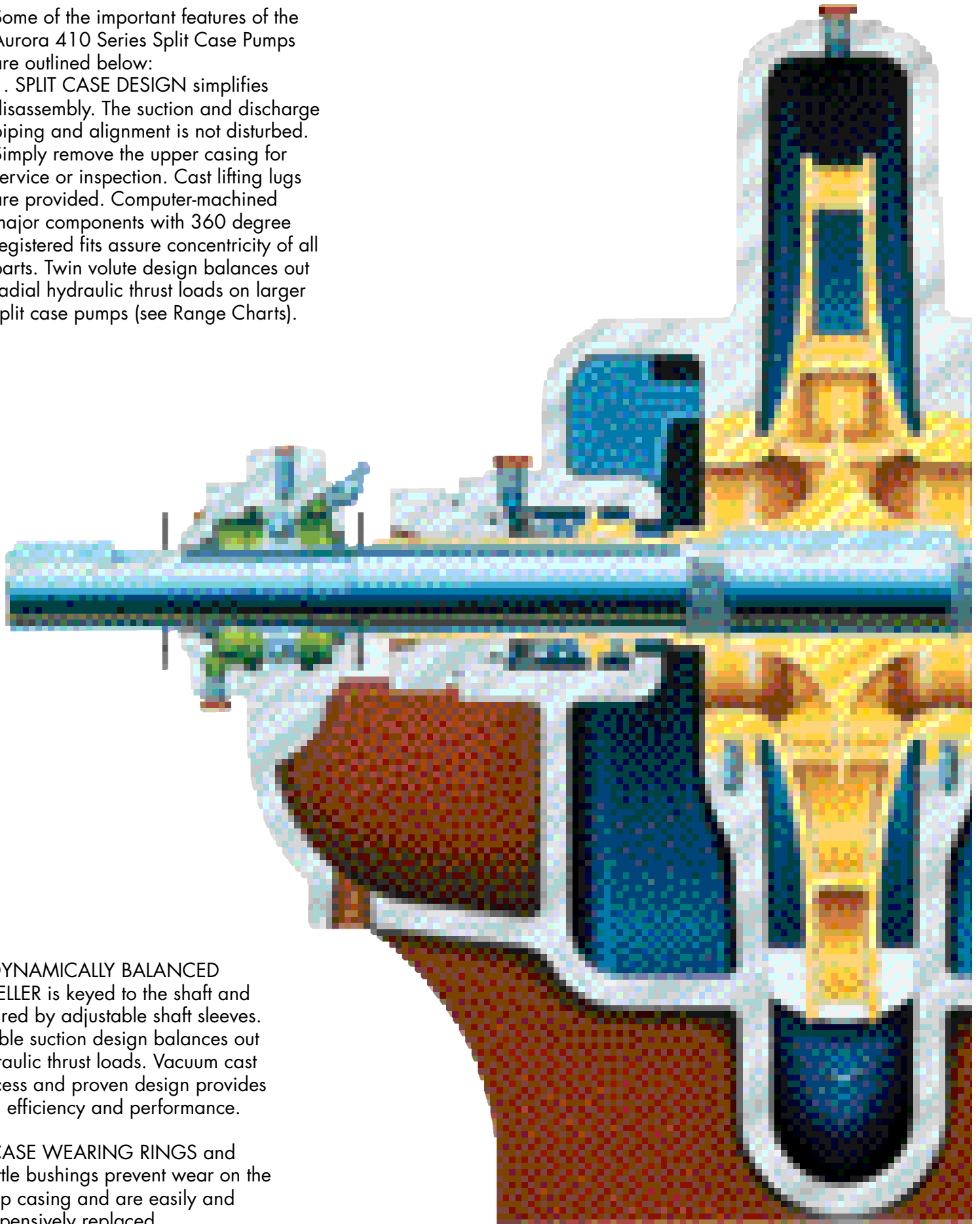

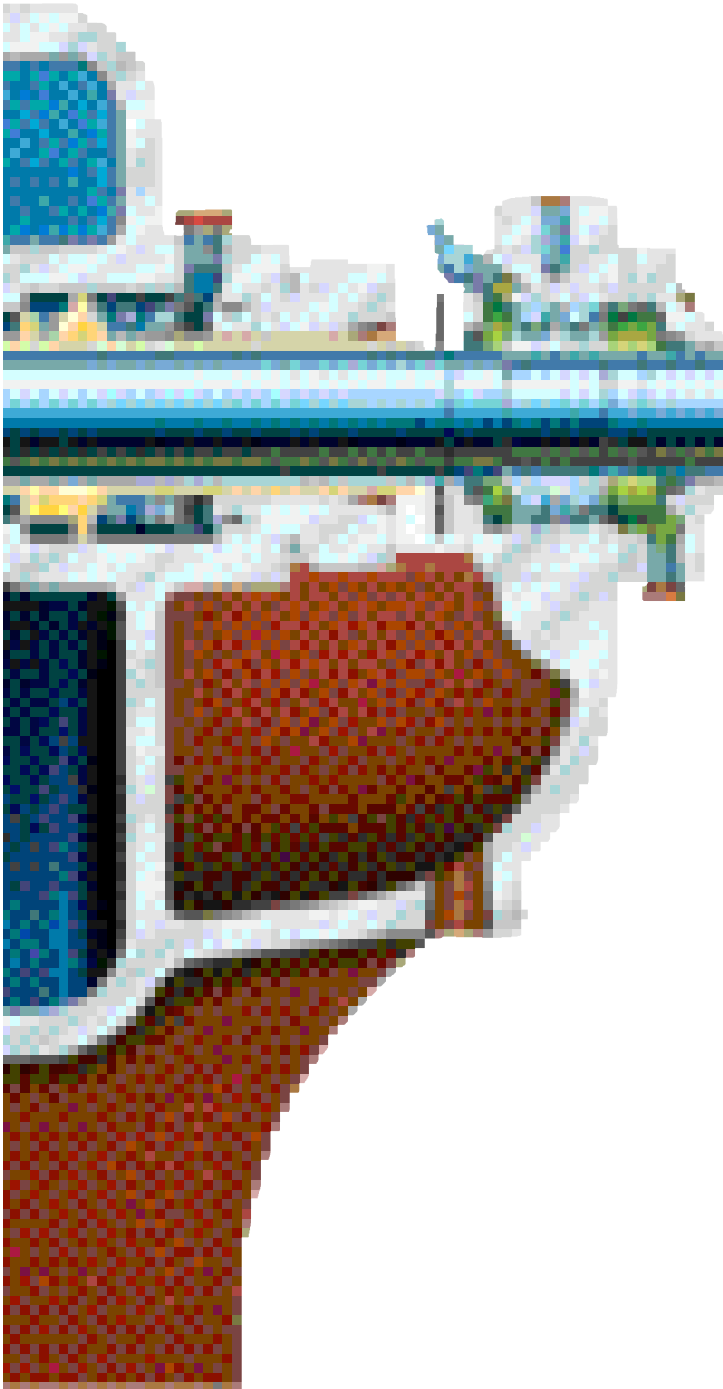

4. BRONZE SHAFT SLEEVE prevents shaft wear, is slip fit over the shaft, keylocked, and extends the entire length of each stuffing box. Shaft sleeves and impeller are "O" ring sealed to eliminate corrosion of the shaft by the pumped liquid. This eliminates the need for high cost, special stainless steel or monel shafts.

5. INTERCHANGEABLE STUFFING BOX for mechanical seals or packing. Packing is standard on horizontal pumps. Optional lantern rings have internal water seal passages between the casing and stuffing box and cannot be damaged. Mechanical seals have carbon against Ni-Resist face. Long life is assured with 303 stainless steel metal parts and "Buna-N" elastomers. Several optional mechanical seals are available.

6. GREASE LUBRICATION purges old grease from bearing. Oil lubrication is optional on horizontal pumps. Lube fittings are conveniently located for quick access and provide positive bearing lubrication. Oil seals and non-sparking Neoprene rotating slingers protect both bearings during pump operation and washdowns.

7. BEARINGS selected for 50,000 hour minimum life at maximum load. Average bearing life 5 x minimum. Double row thrust ball bearing is standard on all models. Short bearing span holds shaft deflection to .002" at face of stuffing box at maximum load. Integral bearing arms eliminate bearing misalignment and simplify service.

8. LEFT HAND ROTATION can be readily provided with standard parts. Tandem drive pumps require only a different shaft.

9. CERTIFIED PERFORMANCE with POSITIVE SUCTION PRESSURE or with a SUCTION LIFT are available on each pump for customer approval. Pumps are all hydrostatically tested.

Engineering Specifications

MODEL 411-412 AND 413 SPLIT CASE BASE MOUNTED

Furnish and install as shown on the plans Right hand (Left hand) Aurora Model (Horizontal-411) (Vertical-412 Open Shaft) (Vertical-413 Flexible Coupled) type Split-Case, Double Suction, Single Stage centrifugal pump, Sizex..... of bronze fitted (all bronze) (all iron) (stainless steel) construction. The pump shall be capable of delivering at design conditions a capacity of G.P.M. when operating against a Total Dynamic Head of feet, with a temperature of °F, specific gravity Pump shall have minimum guaranteed efficiency at design capacity of%. Pump must also be capable of delivering a maximum of G.P.M. when operating against a head of feet, and at this condition shall have a minimum efficiency of%. Minimum shut off head acceptable will be feet. Pump shall operate at a maximum synchronous speed of R.P.M. A unit operating at a lesser rotative speed will be considered, but in no event will a pump operating at more then the maximum speed specified be acceptable. The pump casing halves shall be of the inline piping design and will be constructed of "APCO-LOY 33," C.I. having a minimum tensile strength of 30,000 psi. and shall be of sufficient thickness to withstand stresses and strains at full operating pressures. Casings shall be subject to a hydrostatic pressure test at 150% of the specified duty point. Bearing housing supports, suction and discharge flanges shall be integrally cast with the lower half of the casing. Removal of the upper half of the casing must allow the rotating element to be removed without disconnecting the suction and discharge flanges. The upper casing is to be dowel aligned to the lower casing. Pump sizes 10" and larger are to be of the twin volute design. Drain openings must be provided in the bearing arms for removal of lubricating liquid. Impeller shall be of the enclosed double suction type and shall be vacuum cast bronze(.....). Impeller shall be dynamically balanced and

securely fastened to the shaft by key and screw locked shaft sleeves. The vanes shall be designed to reduce noise. The pump shaft shall be made of high grade SAE 1045 Steel or equal, accurately machined to give a true running rotating element. The minimum dia. acceptable will be". The shaft shall be protected from wear by bronze(.....) sleeves which are key locked and threaded so that the sleeves tighten with the rotation of the shaft. Buna o-rings must be provided between the impeller hub and the shaft sleeves to prevent pumped liquid from corroding the shaft. Pump shall be equipped with easily renewable bronze(.....) casing rings (impeller wearing rings) so designed that hydraulic pressure will seat them against a shoulder in the pump case around the full periphery of the wearing ring. The wear rings will be locked in place by the doweling to prevent rotation. The rotating element shall be mounted in heavy duty grease lubricated ball bearings and shall be equipped with water strainers on side next to pump glands. Bearing housings shall be so designed to flush lubricant through and provide continuous cleaning of bearing surfaces and maximum protection against overheating. The pump shall be supplied with a single row inboard bearing primarily for radial loads and double row outboard bearing primarily for thrust loads. Both bearings shall be regreaseable lubrication ball type, designed for 250,000 hours average life. Each bearing shall be mounted in a machined housing that is moisture and dust proof. The housing shall have registered fits to assure alignment, pinned to prevent rotation, and bolted to the bearing arms. Each housing shall be supplied with a grease fitting and a plugged relief port. **MODEL 411** - Stuffing boxes shall be placed on both sizes of the pump centerline to seal the pump shaft. All packed pumps having a suction lift shall be provided with lantern rings connected to the pressure side of the pump by cored passages in the parting flange of the pump. The stuffing boxes shall be

equipped with heavy, cast, split glands with extra length, for easy removal for packing inspection and maintenance. Pump and motor shall be mounted on a common heavy base plate of (steel with drip rim) (formed steel) (structural steel). Pump and motor must be checked for alignment after the pump base has been installed and grouted in place, in accordance with the standards of the Hydraulic Institute. There shall be no strain transmitted to the pumps. **MODEL 412 AND 413** - Mechanical seal boxes shall be placed on both sides of the pump centerline to seal the pump shaft. Each pump is to be furnished with mech. seals with all metal parts to be 303 stainless steel with "Buna-N" elastomers, Ni-Resist seat, and carbon washer. A bypass line must be provided for the upper seal between the seal faces and the discharge flange to assure adequate venting of the seal chamber and to provide lubrication. All pumps shall be provided with cored passages in the parting flange of the pump to provide additional circulation to both seals. The mech. seal boxes shall be equipped with heavy, cast, one piece "O" ring sealed glands. The pump shall be supported by a cast iron drip rim base. **MODEL 412**- Vertical open shaft pumps are to be driven through flexible shafting with dia. tubing, and intermediate bearings. Shafting must be of sufficient size to transmit required H.P. and must be provided with a slip spline which will permit removal of the pump rotating assembly without removing any section of intermediate shafting, bearings, suction or discharge piping. **MODEL 413**- Vertical flexible coupled pumps shall be furnished with a cast iron motor bracket which is to be bolted to the vertical casing. The motor bracket must be machined with a register fit to insure proper alignment of motor and pump shaft. **MODEL 411 AND 413**-The pumps shall be flexible coupled to a standard (horizontal) (vertical) NEMA.....HP.....phase.....Hertz..... volts.....RPM (drip-proof) (tot. encl.) (explosion-proof) motor.

NOTE: Aurora Pump reserves the right to make revisions to its products and their specifications, and to this bulletin and related information without notice.

— Your Authorized Local Distributor —

WEMA



MARKETING & SALES:
800 AIRPORT ROAD • NORTH AURORA, ILLINOIS U.S.A. • 60542
PHONE: (630) 859-7000 U.S.A./CANADA FAX: (630) 859-7060
WORLDWIDE FAX: (630) 859-1226

AURORA MFG. PLANT:
800 AIRPORT ROAD • NORTH AURORA, ILLINOIS U.S.A. • 60542

SALES OFFICES IN ALL MAJOR CITIES AND COUNTRIES
Refer to "Pumps" in yellow pages of your phone directory
for your local Distributor

ap AURORA®
Pentair Water

