

# AURORA MODEL 412 PUMPS

2" THRU 10" PUMPS

POWER SERIES NO. 1-2-3-4-4A-5-5A-6B

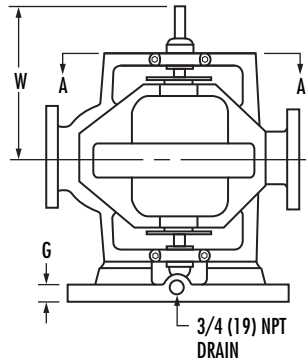
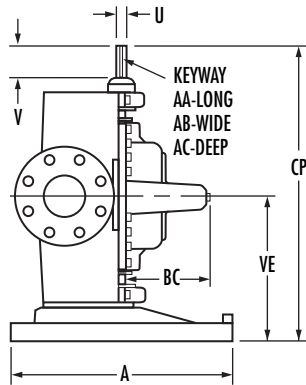

STD. 125# FLANGES	OPT. 250# FLANGES
-------------------	-------------------

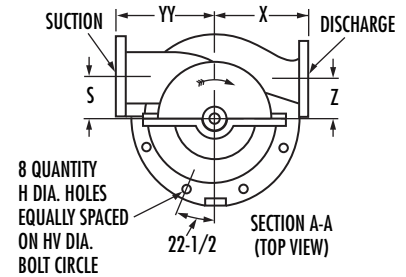

**RIGHT HAND ROTATION**

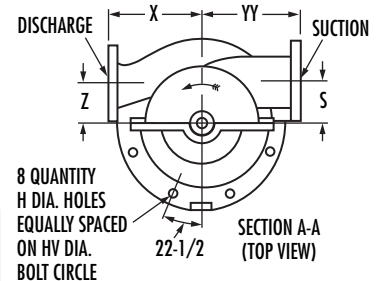

**LEFT HAND ROTATION**

PUMP SIZE			POWER SERIES	BASE	S	U	V	W	X	Z	AA	AB	AC	BC	CP	VE	YY
DISCH	SUCT	CASE BORE															
2	2-1/2	9	1	1	3-1/2 (89)	3/4 (19)	3-1/2 (89)	11-5/8 (295)	8-1/2 (216)	3-1/2 (89)	2 (51)	3/16 (5)	3/32 (2)	6-3/8 (162)	22-3/4 (578)	11-1/8 (283)	9 (227)
2	2-1/2	10	1	1	3-1/2 (89)	3/4 (19)	3-1/2 (89)	11-5/8 (295)	8-1/2 (216)	3-1/2 (89)	2 (51)	3/16 (5)	3/32 (2)	6-3/8 (162)	22-3/4 (578)	11-1/8 (283)	9 (227)
2	2-1/2	12	1	1	4 (102)	3/4 (19)	3-1/2 (89)	11-5/8 (295)	10 (254)	4 (102)	2 (51)	3/16 (5)	3/32 (2)	7-7/8 (200)	22-3/4 (578)	11-1/8 (283)	10-3/4 (273)
2-1/2	3	10	2	1	4 (102)	1-1/8 (29)	2-7/8 (73)	13-1/2 (343)	9-3/4 (248)	4 (102)	2 (51)	1/4 (6)	1/8 (3)	8 (203)	26-1/2 (673)	13 (330)	10 (254)
2-1/2	3	12	2	1	4-1/2 (114)	1-1/8 (29)	2-7/8 (73)	13-1/2 (343)	11 (279)	4-1/2 (114)	2-1/8 (54)	1/4 (6)	1/8 (3)	8-1/4 (209)	26-1/2 (673)	13 (330)	11-1/2 (292)
3	4	10	2	1	4-1/2 (114)	1-1/8 (29)	2-7/8 (73)	13-1/2 (343)	10 (254)	4-1/2 (114)	2-1/8 (54)	1/4 (6)	1/8 (3)	7-3/16 (183)	26-1/2 (673)	13 (330)	11 (279)
3	4	14	2	1	5 (127)	1-1/8 (29)	2-7/8 (73)	13-1/2 (343)	12 (305)	5 (127)	2-1/8 (54)	1/4 (6)	1/8 (3)	9-3/8 (238)	26-1/2 (673)	13 (330)	13 (330)
4	5	10	2	1	4-5/8 (117)	1-1/8 (29)	2-7/8 (73)	13-1/2 (343)	10 (254)	4-1/2 (114)	2-1/8 (54)	1/4 (6)	1/8 (3)	7-3/16 (183)	26-1/2 (673)	13 (330)	11-1/4 (286)
4	5	11	3	2	5 (127)	1-3/8 (35)	3 (76)	14-1/2 (356)	11-1/4 (286)	5 (127)	2-3/8 (60)	3/8 (10)	3/16 (5)	8-5/16 (211)	28-1/2 (724)	14 (356)	12-3/4 (324)
4	5	11D	3	2	5 (127)	1-3/8 (35)	3 (76)	14-1/2 (356)	12 (305)	5 (127)	2-3/8 (60)	3/8 (10)	3/16 (5)	8-5/16 (211)	28-1/2 (724)	14 (356)	12-3/4 (324)
4	5	15	3	2	5-1/2 (140)	1-3/8 (35)	3 (76)	14-1/2 (356)	13 (330)	5-1/2 (140)	2-3/8 (60)	3/8 (10)	3/16 (5)	9 (227)	28-1/2 (724)	14 (356)	14 (356)
4	6	18	4	2	6-1/4 (159)	1-1/2 (38)	3-1/2 (89)	16 (406)	14 (356)	6-1/4 (159)	2-7/8 (73)	3/8 (10)	3/16 (5)	11-3/4 (298)	31 (787)	15 (381)	16 (406)
5	6	11	4	2	5-1/2 (140)	1-1/2 (38)	3-1/2 (89)	16 (406)	11-1/4 (286)	5-1/2 (140)	2-7/8 (73)	3/8 (10)	3/16 (5)	8-3/4 (222)	31 (787)	15 (381)	13-1/4 (337)
5	6	15	4	2	6-1/4 (159)	1-1/2 (38)	3-1/2 (89)	16 (406)	13-1/4 (337)	6-1/4 (159)	2-7/8 (73)	3/8 (10)	3/16 (5)	10-1/16 (256)	31 (787)	15 (381)	15 (381)
5	6	17	4	2	6-1/4 (159)	1-1/2 (38)	3-1/2 (89)	16 (406)	14 (356)	6-1/4 (159)	2-7/8 (73)	3/8 (10)	3/16 (5)	10-1/16 (256)	31 (787)	15 (381)	15 (381)
6	8	11	4	2	6-1/4 (159)	1-1/2 (38)	3-1/2 (89)	16 (406)	11-3/4 (298)	6-1/4 (159)	2-7/8 (73)	3/8 (10)	3/16 (5)	9-1/4 (235)	31 (787)	15 (381)	14-1/2 (356)
6	8	11HH	4A	2	8-5/8 (219)	1-1/2 (38)	3-1/2 (89)	18-1/8 (461)	10 (254)	8-5/8 (219)	2-11/16 (69)	3/8 (10)	3/16 (5)	9-7/16 (240)	35-1/4 (896)	17-1/8 (436)	15 (381)
6	8	14HH	5A	3	7-1/2 (191)	1-3/4 (44)	4-1/8 (105)	20-7/16 (519)	15 (381)	7-1/2 (191)	3-3/8 (86)	3/8 (10)	3/16 (5)	10-3/16 (258)	39-7/8 (1013)	19-7/16 (494)	17 (432)
8	8	11	4	2	6-1/4 (159)	1-1/2 (38)	3-1/2 (89)	16 (406)	12 (305)	6-1/4 (159)	2-7/8 (73)	3/8 (10)	3/16 (5)	9-3/4 (248)	31 (787)	15 (381)	14-1/2 (356)
6	8	15	5	3	6-3/4 (171)	1-3/4 (44)	4 (102)	18 (457)	14-1/4 (362)	6-3/4 (171)	2-7/8 (73)	3/8 (10)	3/16 (5)	11-5/16 (287)	35 (889)	17 (432)	16-3/4 (425)
6	8	18	5	3	8 (203)	1-3/4 (44)	4 (102)	18 (457)	16 (406)	8 (203)	2-7/8 (73)	3/8 (10)	3/16 (5)	12-1/2 (318)	35 (889)	17 (432)	18 (457)
8	8	20	5	3	8 (203)	1-3/4 (44)	4 (102)	18 (457)	15-3/4 (400)	8 (203)	2-7/8 (73)	3/8 (10)	3/16 (5)	12-15/16 (329)	35 (889)	17 (432)	18 (457)
8	10	12	5	3	8 (203)	1-3/4 (44)	4 (102)	18 (457)	17 (432)	9 (227)	2-7/8 (73)	3/8 (10)	3/16 (5)	11-9/16 (294)	35 (889)	17 (432)	17-3/4 (438)
8	10	15	5	3	8 (203)	1-3/4 (44)	4 (102)	18 (457)	17 (432)	9 (227)	2-7/8 (73)	3/8 (10)	3/16 (5)	11-13/16 (300)	35 (889)	17 (432)	17-3/4 (438)
8	10	17	5	3	8 (203)	1-3/4 (44)	4 (102)	18 (457)	17 (432)	8 (203)	2-7/8 (73)	3/8 (10)	3/16 (5)	12-3/8 (314)	35 (889)	17 (432)	17-3/4 (438)

BASE	1	2	3	4
A	18 (457)	22 (559)	30 (762)	40 (1016)
G	1-3/4 (44)	1-3/4 (44)	2 (51)	2-1/4 (57)
H	3/4 (19)	3/4 (19)	7/8 (22)	7/8 (22)
HV	16-1/4 (413)	20 (508)	28 (711)	38 (965)

- NOTES:
- All dimensions in inches (mm).
  - Dimensions may vary ± 3/8" (10).
  - Not for construction purposes unless certified.
  - Discharge and suction flanges - ANSI Standard flat face.

# AURORA MODEL 412-C PUMPS

10"-12"-14" PUMPS

Date **February 2007**

POWER SERIES NO. 6B-7-7A

Supersedes Section 410 Page 205  
Dated January 2003

VERTICAL CHAIR MOUNTED

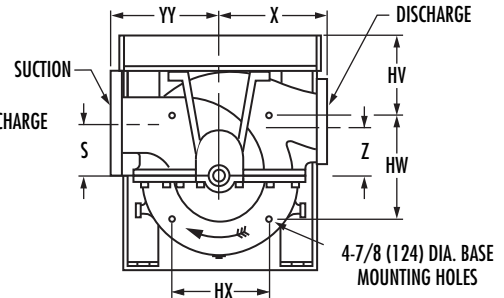
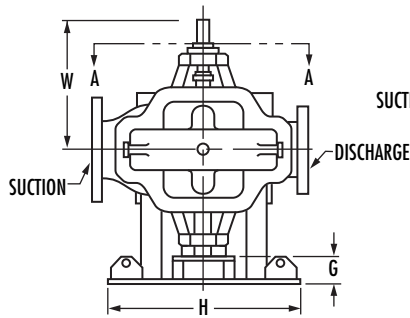
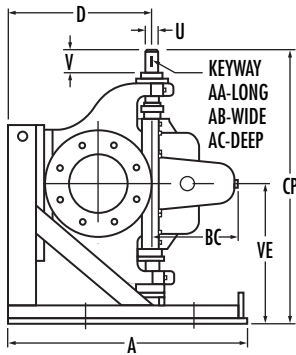

**RIGHT HAND ROTATION**

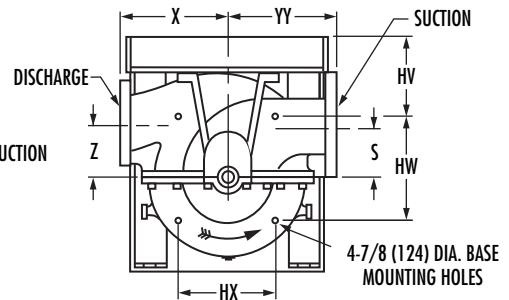
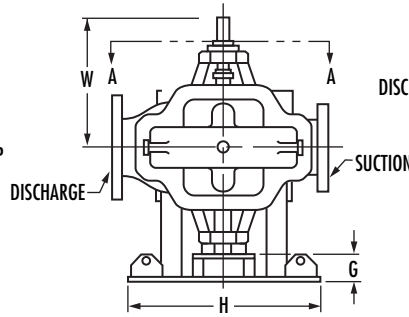
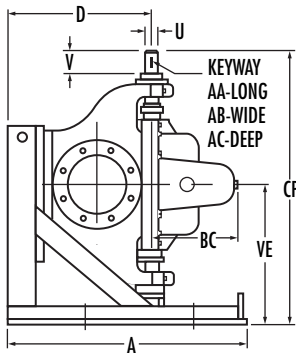

**LEFT HAND ROTATION**

PUMP SIZE			POWER SERIES	BASE	D	S	U	V	W	X	Z	AA	AB	AC	BC	CP	VE	YY
DISCH	SUCT	CASE BORE																
8	10	21	6B	4	25-1/4 (641)	9-1/2 (241)	2-1/8 (54)	5-7/16 (138)	21-7/8 (556)	18 (457)	9-1/2 (241)	4-3/4 (121)	1/2 (13)	1/4 (6)	14 (356)	47 (1194)	25-1/8 (638)	21 (533)
10	12	15	6B	1	31-3/4 (806)	13-1/2 (343)	2-1/8 (54)	5-7/16 (138)	21-7/8 (556)	17 (432)	13-1/2 (343)	4-3/4 (121)	1/2 (13)	1/4 (6)	13-1/2 (343)	47 (1194)	25-1/8 (638)	20 (508)
10	12	18	6B	1	31-3/4 (806)	13-1/2 (343)	2-1/8 (54)	5-7/16 (138)	21-7/8 (556)	18 (457)	13-1/2 (343)	4-3/4 (121)	1/2 (13)	1/4 (6)	14-1/2 (368)	47 (1194)	25-1/8 (638)	22 (559)
10	12	18D	7A	5	31-3/4 (806)	12-1/4 (311)	2-1/8 (54)	6-5/16 (160)	24-5/16 (556)	20 (508)	12-1/4 (311)	4-3/4 (121)	1/2 (13)	1/4 (6)	15-1/16 (383)	52 (1321)	27-5/8 (702)	24 (610)
12	14	15	7	2	33-3/4 (857)	15 (381)	2-1/2 (64)	6-5/8 (168)	25-1/4 (641)	17 (432)	15 (381)	5 (127)	5/8 (16)	5/16 (8)	15 (381)	51-1/4 (1302)	26 (660)	22 (559)
12	14	18	7	2	33-3/4 (857)	15 (381)	2-1/2 (64)	6-5/8 (168)	25-1/4 (641)	18 (457)	15 (381)	5 (127)	5/8 (16)	5/16 (8)	16-1/8 (410)	51-1/4 (1302)	26 (660)	23 (584)
14	16	18	7	3	36 (914)	16 (406)	2-1/2 (64)	6-5/8 (168)	25-1/4 (641)	22 (559)	16 (406)	5 (127)	5/8 (16)	5/16 (8)	18-1/4 (464)	51-1/4 (1302)	26 (660)	27 (686)

BASE	1	2	3	4	5
A	38 (965)	46 (1168)	48 (1219)	40 (1016)	50 (1270)
G	9-5/8 (244)	8 (203)	8 (203)	9-5/8 (244)	9-5/8 (245)
H	36-1/2 (927)	35 (889)	35 (889)	36-1/2 (927)	44-1/2 (1130)
HV	8 (203)	8 (203)	8 (203)	8 (203)	8 (203)
HW	26 (660)	34 (864)	36 (914)	28 (711)	34 (864)
HX	22 (559)	19 (483)	19 (483)	22 (559)	22 (559)

STD. 125# FLANGES	OPT. 250# FLANGES
-------------------	-------------------

**NOTES:**

- All dimensions in inches (mm).
- Dimensions may vary  $\pm 3/8"$  (10).
- Not for construction purposes unless certified.
- Discharge and suction flanges - ANSI Standard flat face.

# AURORA MODEL 412 & 413

## BASEPLATE DIMENSIONS

Section **410** Page **209**

Date **January 2003**

Supersedes Section 410 Page 209  
Dated March 1981

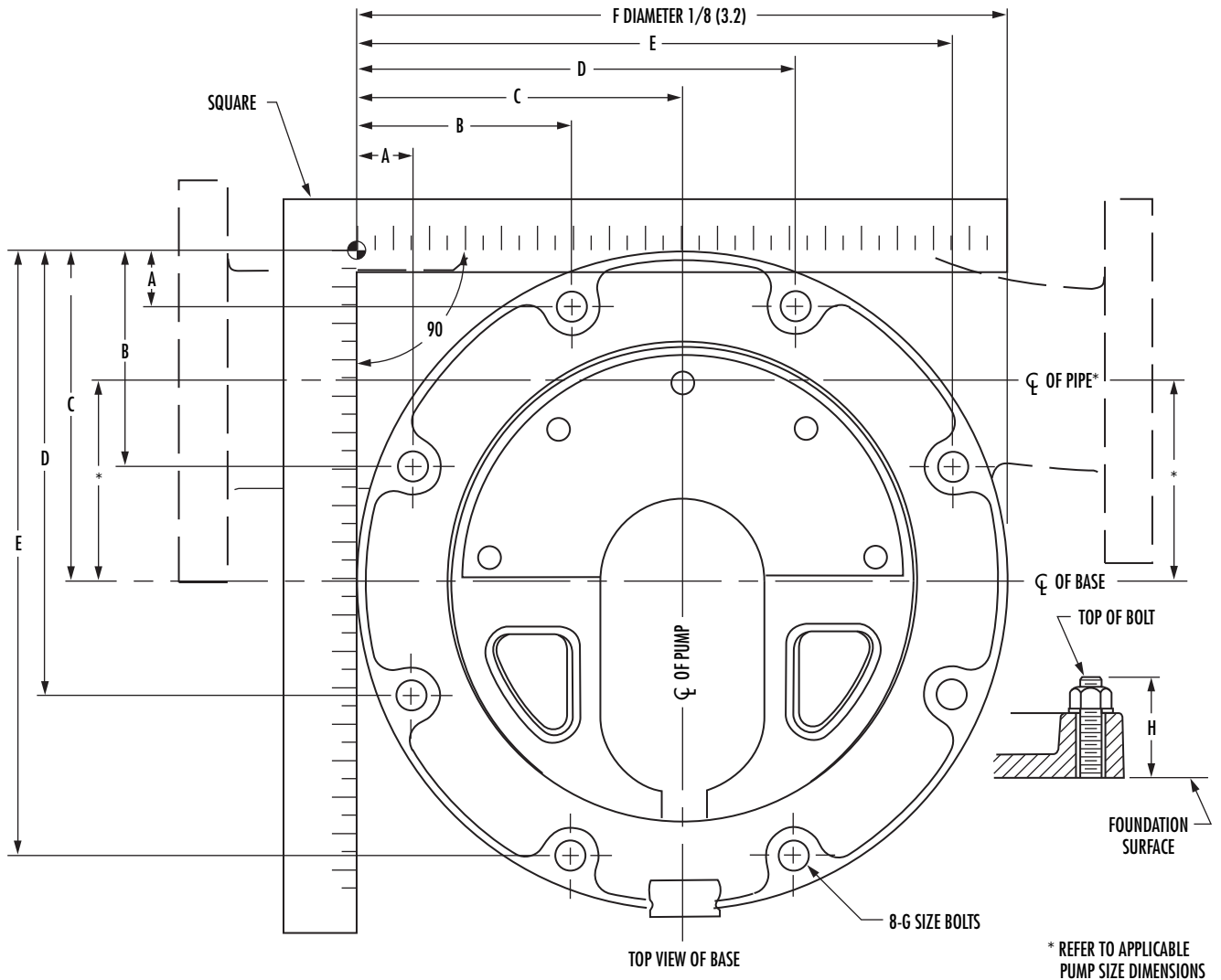

BASE	A	B	C	D	E	F	G	H	FULL SCALE TEMPLATE
1	1-1/2 (38)	5-29/32 (150)	9 (229)	12-1/8 (308)	16-1/2 (419)	18 (457)	5/8 (16)	2-3/4 (70)	294-0579-000
2	1-25/32 (45)	7-3/16 (183)	11 (279)	14-27/32 (377)	20-1/4 (514)	22 (559)	5/8 (16)	2-3/4 (70)	294-0580-000
3	2-1/16 (52)	9-21/32 (245)	15 (381)	20-3/8 (518)	27-15/16 (710)	30 (762)	3/4 (19)	3-1/4 (83)	294-0581-000
4	2-7/16 (62)	12-23/32 (323)	20 (508)	27-9/32 (693)	37-9/16 (954)	40 (1016)	3/4 (19)	3-1/2 (89)	294-0613-000

**NOTES:**

1. All dimensions in inches (mm).
2. Dimensions may vary  $\pm 3/8"$  (10).
3. Not for construction purposes unless certified.
4. Discharge and suction flanges - ANSI Standard flat face.