

AURORA MODEL 413 PUMPS

2" THRU 4" PUMPS
POWER SERIES NO. 1-2-3

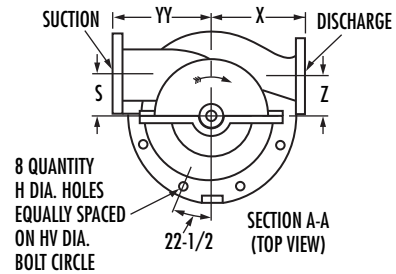

RIGHT HAND ROTATION

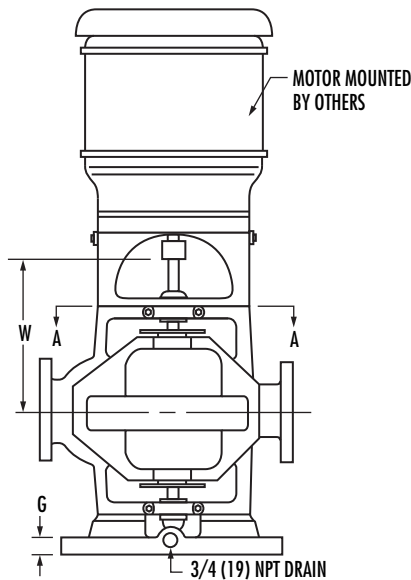
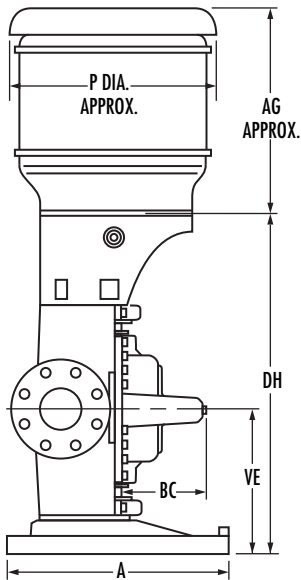
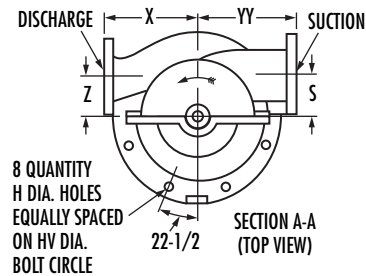

LEFT HAND ROTATION

PUMP SIZE				POWER SERIES	BASE	S	W	X	Z	BC	VE	YY
DISCH	SUCT	CASE BORE										
2	2-1/2	9	1	1	3-1/2 (89)	11-5/8 (295)	8-1/2 (216)	3-1/2 (89)	6-3/8 (162)	11-1/8 (283)	9 (228)	
2	2-1/2	10	1	1	3-1/2 (89)	11-5/8 (295)	8-1/2 (216)	3-1/2 (89)	6-3/8 (162)	11-1/8 (283)	9 (228)	
2	2-1/2	12	1	1	4 (102)	11-5/8 (295)	10 (254)	4 (102)	7-7/8 (200)	11-1/8 (283)	10-3/4 (273)	
2-1/2	3	10	2	1	4 (102)	13-1/2 (343)	9-3/4 (247)	4 (102)	8 (203)	13 (330)	10 (254)	
2-1/2	3	12	2	1	4-1/2 (114)	13-1/2 (343)	11 (279)	4-1/2 (114)	8-1/4 (210)	13 (330)	11-1/2 (292)	
3	4	10	2	1	4-1/2 (114)	13-1/2 (343)	10 (254)	4-1/2 (114)	7-3/16 (183)	13 (330)	11 (279)	
3	4	14	2	1	5 (127)	13-1/2 (343)	12 (305)	5 (127)	9-3/8 (238)	13 (330)	13 (330)	
4	5	10	2	1	4-5/8 (117)	13-1/2 (343)	10 (254)	4-1/2 (114)	7-3/16 (183)	13 (330)	11-1/4 (286)	
4	5	11A/C	3	2	5 (127)	14-1/2 (368)	11-1/4 (286)	5 (127)	8-5/16 (211)	14 (356)	12-3/4 (324)	
4	5	11D	3	2	5 (127)	14-1/2 (368)	12 (305)	5 (127)	8-5/16 (211)	14 (356)	12-3/4 (324)	
4	5	15	3	2	5-1/2 (140)	14-1/2 (368)	13 (330)	5-1/2 (140)	9 (228)	14 (356)	14 (356)	

BASE	1	2	3	4
A	18 (457)	22 (558)	30 (762)	40 (1016)
G	1-3/4 (44)	1-3/4 (44)	2 (51)	2-1/4 (57)
H	3/4 (19)	3/4 (19)	7/8 (22)	7/8 (22)
HV	16-1/4 (413)	20 (508)	28 (711)	38 (965)

STD. 125# FLANGES	OPT. 250# FLANGES
-------------------	-------------------

FRAME	143	145	182	184	213	215	254	256	284	286	324	326	364	365	404	405	444	445
	P	8 (203)	8 (203)	10 (254)	10 (254)	11 (279)	11 (279)	13 (330)	13 (330)	16 (406)	16 (406)	18 (457)	18 (457)	21 (534)	21 (534)	22 (559)	22 (559)	24 (610)
AG	11 (279)	12 (305)	14 (356)	15 (381)	16 (406)	17 (432)	20 (508)	21 (534)	22 (559)	23 (584)	25 (635)	26 (660)	25 (635)	25 (635)	28 (711)	28 (711)	32 (813)	32 (813)
PUMP SIZE		DH																
2 x 2-1/2 x 9		26 (660)										28 (711)		NOT AVAILABLE				
2 x 2-1/2 x 10																		
2 x 2-1/2 x 12																		
2-1/2 x 3 x 10																		
2-1/2 x 3 x 12		30 (762)										32 (813)		NOT AVAILABLE				
3 x 4 x 10																		
3 x 4 x 14																		
4 x 5 x 10																		
4 x 5 x 11		33 (838)										35 (889)		NA				
4 x 5 x 15																		

NOTES:

- All dimensions in inches (mm).
- Dimensions may vary $\pm 3/8"$ (10).
- Not for construction purposes unless certified.
- Coupling gap may vary 1/8" (3) to 1" (25)
- Height (AG) and diameter (P) dimensions of motor will vary based on make and style of motor. DIMENSIONS SHOWN REFLECT AURORA STANDARD MOTORS. See individual motor supplier dimensional data sheets for your application.
- Conduit box is shown in approximate location. Dimensions are not specified as they vary for each motor manufacturer.
- Discharge and suction flanges - ANSI Standard flat face.

AURORA MODEL 413 PUMPS

4" THRU 10" PUMPS
POWER SERIES NO. 4-5-6B

Date February 2007

Supersedes Section 410 Page 207
Dated January 2003

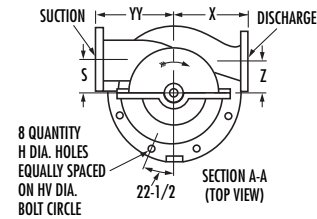
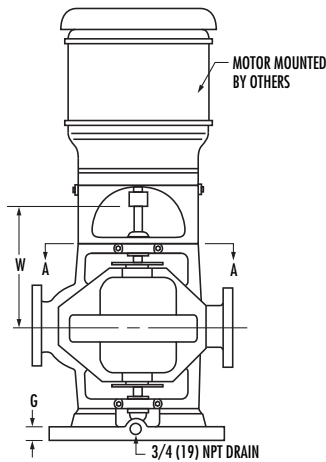
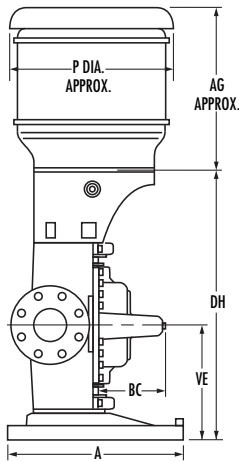

RIGHT HAND ROTATION

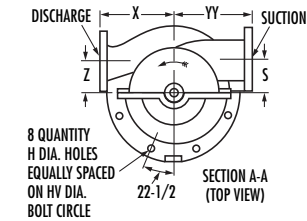

LEFT HAND ROTATION

PUMP SIZE											
DISCH	SUCT	CASE BORE	POWER SERIES	BASE	S	W	X	Z	BC	VE	YY
4	6	18	4	2	6-1/4 (159)	16 (406)	14 (356)	6-1/4 (1)	11-3/4 (298)	15 (381)	16 (406)
5	6	11	4	2	5-1/2 (140)	16 (406)	11-1/4 (286)	5-1/2 (140)	8-3/4 (222)	15 (381)	13-1/4 (337)
5	6	15	4	2	6-1/4 (159)	16 (406)	13-1/4 (337)	6-1/4 (159)	10-1/16 (256)	15 (381)	15 (381)
5	6	17	4	2	6-1/4 (159)	16 (406)	14 (356)	6-1/4 (159)	10-1/16 (256)	15 (381)	15 (381)
6	8	11	4	2	6-1/4 (159)	16 (406)	11-3/4 (298)	6-1/4 (159)	9-1/4 (235)	15 (381)	14-1/2 (368)
6	8	11HH	4A	2	8-5/8 (219)	18-1/8 (461)	10 (254)	8-5/8 (219)	9-7/16 (240)	17-1/8 (436)	15 (381)
6	8	14HH	5A	3	7-1/2 (191)	20-7/16 (519)	15 (381)	7-1/2 (191)	10-3/16 (258)	19-7/16 (494)	17 (432)
8	8	11	4	2	6-1/4 (159)	16 (406)	12 (305)	6-1/4 (159)	9-3/4 (248)	15 (381)	14-1/2 (368)
6	8	15	5	3	6-3/4 (171)	18 (457)	14-1/4 (362)	6-3/4 (171)	11-5/16 (287)	17 (432)	16-3/4 (425)
6	8	18	5	3	8 (203)	18 (457)	16 (406)	8 (203)	12-1/2 (318)	17 (432)	18 (457)
6	8	20	5	3	8 (203)	18 (457)	15-3/4 (400)	8 (203)	2-15/16 (75)	17 (432)	18 (457)
8	10	12	5	3	8 (203)	18 (457)	17 (432)	9 (228)	11-9/16 (294)	17 (432)	17-3/4 (451)
8	10	15	5	3	8 (203)	18 (457)	17 (432)	9 (228)	11-13/16 (300)	17 (432)	17-3/4 (451)
8	10	17	5	3	8 (203)	18 (457)	17 (432)	8 (203)	12-3/8 (314)	17 (432)	17-3/4 (451)
10	12	12B	6B	4	12 (305)	21-7/8 (457)	16 (406)	12 (305)	12-1/2 (318)	19 (483)	19 (483)

BASE	1	2	3	4
A	18 (457)	22 (558)	30 (762)	40 (1016)
G	1-3/4 (44)	1-3/4 (44)	2 (51)	2-1/4 (57)
H	3/4 (19)	3/4 (19)	7/8 (22)	7/8 (22)
HV	16-1/4 (413)	20 (508)	28 (711)	38 (965)

	STD. 125# FLANGES	OPT. 250# FLANGES

FRAME	143	145	182	184	213	215	254	256	284	286	324	326	364	365	404	405	444	445
	P	8 (203)	8 (203)	10 (254)	10 (254)	11 (279)	11 (279)	13 (330)	13 (330)	16 (406)	16 (406)	18 (457)	18 (457)	21 (534)	21 (534)	22 (559)	22 (559)	24 (610)
AG	11 (279)	12 (305)	14 (356)	15 (381)	16 (406)	17 (432)	20 (508)	21 (559)	22 (584)	23 (584)	25 (635)	26 (660)	25 (635)	25 (635)	28 (711)	28 (711)	32 (813)	32 (813)
PUMP SIZE																		
4 x 6 x 18																		
5 x 6 x 11																		
5 x 6 x 15																		35 (889)
5 x 6 x 17																		
6 x 8 x 11																		
8 x 8 x 11																		
6x8x11HH	NOT AVAILABLE																	41-1/4 (1049)
6x8x14HH	NOT AVAILABLE																	45-7/8 (1166)
6 x 8 x 15																		
6 x 8 x 18																		
6 x 8 x 20	NOT AVAILABLE																	41 (1041)
8 x 10 x 12																		
8 x 10 x 15																		
8 x 10 x 17																		
10 x 12 x 12B	NOT AVAILABLE																	46-1/2 (1181)

NOTES:

- All dimensions in inches (mm).
- Dimensions may vary $\pm 3/8"$ (10).
- Not for construction purposes unless certified.
- Coupling gap may vary 1/8" (3) to 1" (25)
- Height (AG) and diameter (P) dimensions of motor will vary based on make and style of motor. DIMENSIONS SHOWN REFLECT AURORA STANDARD MOTORS. See individual motor supplier dimensional data sheets for your application.
- Conduit box is shown in approximate location. Dimensions are not specified as they vary for each motor manufacturer.
- Discharge and suction flanges - ANSI Standard flat face.

AURORA MODEL 412 & 413

BASEPLATE DIMENSIONS

Section **410** Page **209**

Date **January 2003**

Supersedes Section 410 Page 209
Dated March 1981

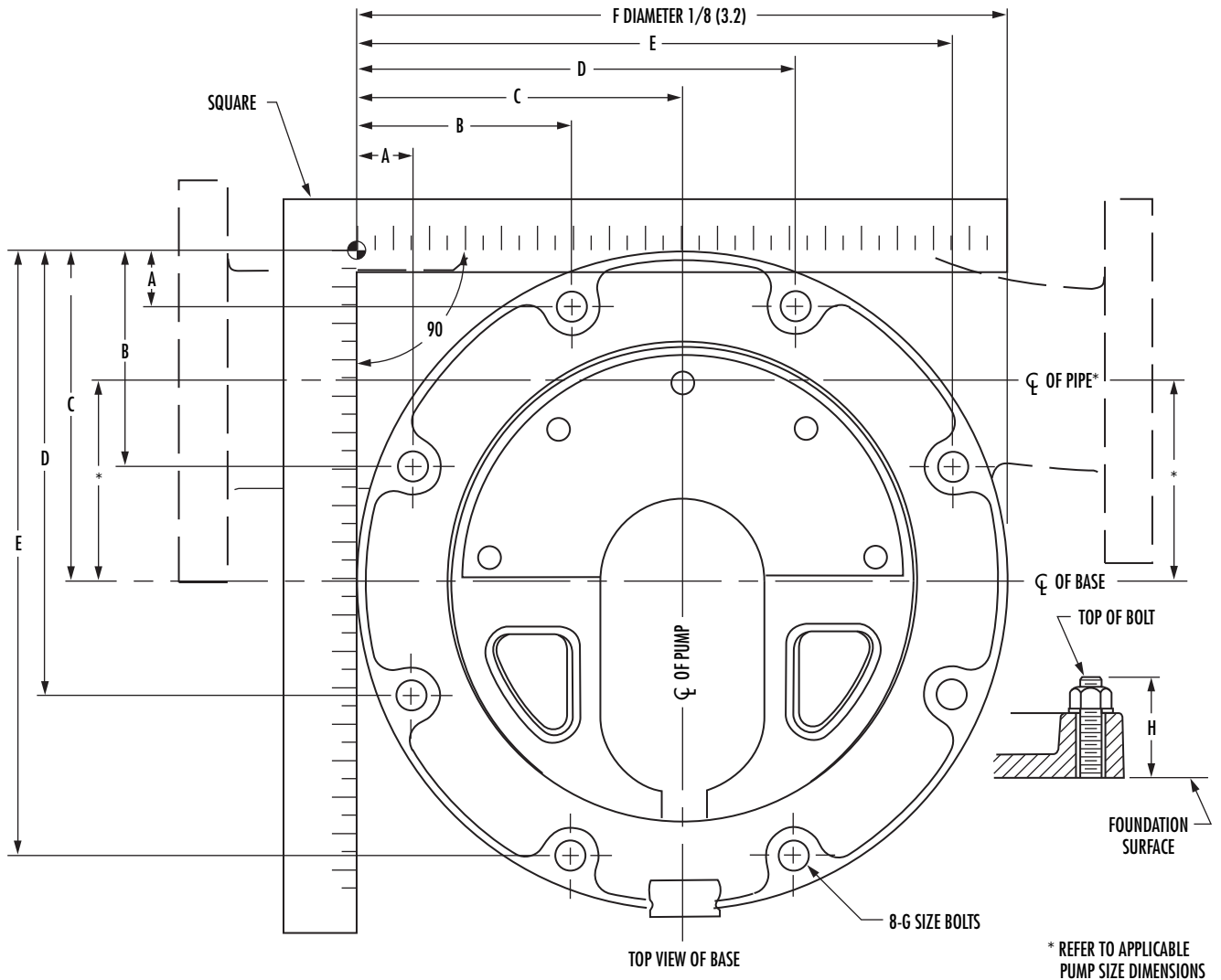

BASE	A	B	C	D	E	F	G	H	FULL SCALE TEMPLATE
1	1-1/2 (38)	5-29/32 (150)	9 (229)	12-1/8 (308)	16-1/2 (419)	18 (457)	5/8 (16)	2-3/4 (70)	294-0579-000
2	1-25/32 (45)	7-3/16 (183)	11 (279)	14-27/32 (377)	20-1/4 (514)	22 (559)	5/8 (16)	2-3/4 (70)	294-0580-000
3	2-1/16 (52)	9-21/32 (245)	15 (381)	20-3/8 (518)	27-15/16 (710)	30 (762)	3/4 (19)	3-1/4 (83)	294-0581-000
4	2-7/16 (62)	12-23/32 (323)	20 (508)	27-9/32 (693)	37-9/16 (954)	40 (1016)	3/4 (19)	3-1/2 (89)	294-0613-000

NOTES:

1. All dimensions in inches (mm).
2. Dimensions may vary $\pm 3/8"$ (10).
3. Not for construction purposes unless certified.
4. Discharge and suction flanges - ANSI Standard flat face.