

Commercial Well Tank Installation Instructions



⚠ WARNING CALIFORNIA PROPOSITION 65 WARNING: This product contains a chemical known by the State of California to cause cancer and to cause birth defects or other reproductive harm. (California Installer/ Contractor - California law requires that this notice be given to consumer/end user of this product.) For more information: www.amtrol.com/prop65/htm.

⚠ WARNING READ CAREFULLY THE PRODUCT INSTALLATION, OPERATING AND MAINTENANCE MANUAL. FAILURE TO FOLLOW THE INSTRUCTIONS AND WARNINGS IN THE MANUAL MAY RESULT IN SERIOUS OR FATAL INJURY AND/OR PROPERTY DAMAGE, AND WILL VOID THE PRODUCT WARRANTY. THIS PRODUCT MUST BE INSTALLED BY A QUALIFIED PROFESSIONAL. FOLLOW ALL APPLICABLE LOCAL AND STATE CODES AND REGULATIONS, IN THE ABSENCE OF SUCH CODES, FOLLOW THE CURRENT EDITIONS OF THE NATIONAL PLUMBING CODE AND NATIONAL ELECTRIC CODE, AS APPLICABLE.

⚠ WARNING EXPLOSION OR RUPTURE HAZARD. THE EXPANSION TANK MUST BE OPERATED SO THAT THE PRESSURE DOES NOT EXCEED THE MAXIMUM WORKING PRESSURE.

⚠ THIS IS A SAFETY ALERT SYMBOL. IT IS USED TO ALERT YOU TO POTENTIAL PERSONAL INJURY AND OTHER HAZARDS. OBEY ALL SAFETY MESSAGES THAT FOLLOW THIS SYMBOL TO REDUCE THE RISK OF POSSIBLE INJURY AS WELL AS PROPERTY DAMAGE.

THIS PRODUCT COMES WITH A LIMITED ONE (1) YEAR WARRANTY, SEE AMTROL'S LIMITED PRODUCT WARRANTY FOR DETAILS.

1. GENERAL SAFETY INFORMATION

⚠ WARNING This Product, like most Products under pressure, may over time corrode, weaken and burst or explode, causing serious or fatal injury, leaking or flooding and/or property damage. To minimize risk, a licensed professional must install and periodically inspect and service the Product. A drip pan connected to an adequate drain must be installed if leaking or flooding could cause property damage. Do not locate in an area where leakage of the tank or connections could cause property damage to the area adjacent to the appliance or to lower floors of the structure.

⚠ CAUTION AS IN ALL PLUMBING PRODUCTS AND WATER STORAGE VESSELS, BACTERIA CAN GROW IN YOUR WELL TANK, ESPECIALLY DURING TIMES OF NON-USE. CONSULT YOUR LOCAL PLUMBING OFFICIAL REGARDING ANY STEPS YOU MAY WISH TO TAKE TO SAFELY DISINFECT YOUR HOME'S PLUMBING SYSTEM.

⚠ WARNING FOLLOW ALL OF THE INSTRUCTIONS AND RECOMMENDATIONS CONTAINED IN THIS MANUAL, AND THE FOLLOWING ADDITIONAL SPECIFIC WARNINGS. FAILURE TO DO SO IS UNSAFE AND CAN CAUSE SERIOUS EXPLOSION, SERIOUS OR FATAL PERSONAL INJURY AND PROPERTY DAMAGE.

⚠ WARNING **EXPLOSION OR RUPTURE HAZARD** A relief valve must be installed to prevent pressure in excess of local code requirement or maximum working pressure designated in the Product Manual, whichever is less. Do not expose Product to freezing temperatures or temperatures in excess of 200° F. Do not adjust the pre-charge or re-pressure this Product except for any adjustments required at the time of initial installation, especially if Product is corroded, damaged or with diminished integrity. Adjustments to pre-charge must be done at ambient temperature only. Failure to properly size the Product or follow these instructions may result in excessive strain on the system lead to Product failure, serious or fatal personal injury, leakage and/or property damage.

⚠ WARNING **MAXIMUM WORKING PRESSURES.** Every Well-X-Trol® is air tested to 125 psig, the maximum working pressure for the Well-X-Trol line. Should pressures exceed 125 psig, proper selection and sizing of an ASME constructed Well-X-Trol should be made.

⚠ WARNING **RELIEF VALVE REQUIRED.** A relief valve should be installed which is set to open at excessive pressures (75psig or more). This will protect the Well-X-Trol® and other system components should the pressure switch malfunction and fail to shut the pump off. The relief valve should be installed at the connection of the Well-X-Trol® to the system piping and have a discharge equal to the pump's capacity at 75 psig.

⚠ WARNING **IMPORTANT GENERAL SAFETY INFORMATION - ADDITIONAL SPECIFIC SAFETY ALERTS APPEAR IN THE FOLLOWING INSTRUCTIONS.**

⚠ WARNING **DANGER! EXPLOSION HAZARD.** IF YOU ADJUST THE PRE-CHARGE PRESSURE OR ADD PRESSURE TO A TANK THAT IS CORRODED OR DAMAGED OR WITH DIMINISHED INTEGRITY THE TANK CAN BURST OR EXPLODE, POSSIBLY CAUSING SERIOUS OR FATAL PERSONAL INJURY AND/OR PROPERTY DAMAGE.

- ONLY ADJUST THE PRE-CHARGE AS DESCRIBED IN THIS MANUAL WHEN THE TANK IS NEW OR WHEN THE INTEGRITY OF THE TANK AND LACK OF INTERNAL OR EXTERNAL CORROSION IS CONFIRMED.
- ONLY QUALIFIED PROFESSIONALS SHOULD CHECK, ADJUST OR RE-CHARGE THE PRE-CHARGE OF TANKS.

⚠ WARNING **DANGER! EXPLOSION HAZARD.** WHEN THE WELL TANK HAS BEEN IN SERVICE AND A CHANGE TO A HIGHER PRE-CHARGE PRESSURE IS NECESSARY DUE TO A REQUIRED CHANGE IN THE PRESSURE SWITCH SETTING, FAILURE TO FOLLOW INSTRUCTIONS BELOW CAN CAUSE A RUPTURE OR EXPLOSION, POSSIBLY CAUSING SERIOUS OR FATAL PERSONAL INJURY, AND/OR PROPERTY DAMAGE.

- DO NOT ADJUST OR ADD PRESSURE IF THERE HAS BEEN A LOSS OF AIR.
- DO NOT ADJUST THE PRE-CHARGE PRESSURE IF THERE IS VISIBLE EXTERIOR CORROSION.
- DO NOT ADJUST THE PRE-CHARGE PRESSURE IF THERE HAS BEEN A REDUCTION OF THE PUMP CYCLE TIME OR THE PRE-CHARGE PRESSURE COMPARED TO ITS INITIAL SETTING. THIS IS BECAUSE REDUCTION IN PUMP CYCLE TIME CAN RESULT FROM LOSS OF TANK AIR PRESSURE WHICH IN TURN CAN MEAN THERE MAY BE INTERNAL CORROSION AND ANY RE-PRESSURIZATION OR ADDITIONAL PRESSURE COULD RESULT IN RUPTURE OR EXPLOSION.

⚠ WARNING THE WATER QUALITY CAN SIGNIFICANTLY INFLUENCE THE LIFE OF YOUR PRODUCT. YOU SHOULD TEST FOR CORROSIVE ELEMENTS, ACIDITY, TOTAL SOLIDS, AND OTHER RELEVANT CONTAMINANTS, INCLUDING CHLORINE AND TREAT YOUR WATER APPROPRIATELY TO INSURE SATISFACTORY PERFORMANCE AND PREVENT PREMATURE FAILURE.

⚠ WARNING A WATER TEST MUST BE TAKEN BEFORE INSTALLATION OF ANY WATER TREATMENT EQUIPMENT.

⚠ WARNING FOR YOUR SAFETY, THE INFORMATION IN THIS MANUAL MUST BE FOLLOWED TO MINIMIZE THE RISK OF ELECTRIC SHOCK, PROPERTY DAMAGE OR PERSONAL INJURY.

- PROPERLY GROUND TO CONFORM WITH ALL GOVERNING CODES AND ORDINANCES.

⚠ WARNING DO NOT INSTALL IN DIRECT SUNLIGHT. EXCESSIVE SUN HEAT MAY CAUSE DISTORTION OR OTHER DAMAGE TO NON-METALLIC PARTS.

⚠ WARNING USE ONLY LEAD-FREE SOLDER AND FLUX FOR ALL SWEAT-SOLDER CONNECTIONS, AS REQUIRED BY STATE AND FEDERAL CODES.

⚠ WARNING MAXIMUM ALLOWABLE INLET WATER PRESSURE IS 125 PSIG. IF DAYTIME PRESSURE IS OVER 80 PSIG, NIGHTTIME PRESSURE MAY EXCEED THE MAXIMUM. USE A PRESSURE-REDUCING VALVE TO REDUCE THE FLOW IF NECESSARY.

⚠ WARNING **ELECTROCUTION AND EXPLOSION HAZARD.** BEFORE WORK IS PERFORMED ON THE TANK, TURN OFF THE POWER TO THE PUMP AND RELEASE ALL WATER PRESSURE IN THE TANK AND PUMPING SYSTEM.

NOTE: INSPECT FOR SHIPPING DAMAGE AND NOTIFY FREIGHT CARRIER OR STORE WHERE PURCHASED IMMEDIATELY IF DAMAGE PRESENT.

NOTE: PLEASE READ THE ENTIRE OWNER'S MANUAL AND INSTALLATION INSTRUCTIONS BEFORE INSTALLING YOUR NEW AMTROL PRODUCT. SAVE ALL DOCUMENTS AND MANUALS FOR FUTURE REFERENCE.

NOTE: USE PROPER SAFETY EQUIPMENT WHEN INSTALLING.

NOTE: YOU MUST COMPLY WITH ALL PLUMBING CODES.

GENERAL INFORMATION

Attaching acceptance fittings:

Models: WX-401(C) through WX-403(C) have a 1" elbow.
 WX-447(C) through WX-452(C) have a 2" elbow.
 WX-404(C) through WX-407(C) have a 1-1/4" elbow.
 WX-453(C) through WX-457(C) have a 3" elbow.
 WX-421 through WX-422 have a 2" elbow.
 WX-423 through WX-427 have a 3" elbow.

Proper WELL-X-TROL® Location

The WELL-X-TROL should be installed as close as possible to the pressure switch. This will reduce the adverse effects of added friction loss and differences in elevation between WELL-X-TROL® and/or water supply main and switch.

Adjusting WELL-X-TROL® Precharge To System Requirements

Models WX-401(C) through WX-407(C) come with a factory pre-charge of 30 psig. Models WX-447(C) through WX-457(C) come with a factory pre-charge of 25 psig. Models WX-421 through WX-427 come with a factory pre-charge of 25 psig.

1. Remove protective air valve cap and using a suitable pressure gauge, check precharge pressure. (Tank should be at room temperature and empty of water.)
2. Release or add air as necessary to make precharge pressure equal to 2 psig below the pressure switch pump cut-in setting or 10%-20% below system pressure for a surge application.

Note: Pressure switch setting may be out-of-adjustment, i.e. If labeled "30/50", it may be actually 28 or 29 to 48 to 49. See "Fine Tuning Procedure" on page 2 for correcting this situation. Do not adjust WELL-X-TROL® precharge for this variation.

3. Replace protective air valve cap and seal with the air valve label provided. (See Figure 1, on page 2) This will enable you to determine if valve has been tampered with on possible future service calls.

When the WELL-X-TROL® is installed in the system, system pressure must be reduced to exhaust the tank of acceptance water before precharging. Once this has been done, follow above steps 1-3. **NOTE:** For high pressure applications see instructions on page 5.

System Connection

1. Locate WELL-X-TROL® in final desired location.
2. Level as necessary.
3. Connect to pump supply line with same size pipe as from pump. Eliminate unnecessary friction loss.
4. All piping should be in accordance with prevailing local codes and standards.

TO "FINE TUNE", FOLLOW THESE STEPS:

1. Fill the system and WELL-X-TROL® until pump cuts off.
2. Open one or more fixtures to drain WELL-X-TROL®.
3. If there is a momentary pause in the water flow from the time the WELL-X-TROL® is emptied and the pump starts, adjust pump switch cut-in setting upward (clockwise) slightly. (Refer to Adjustment Instructions by switch manufacturer).
4. Close fixtures and refill WELL-X-TROL® to pump cut-off. Check time to fill.
5. Open fixtures and see if pause in water is eliminated at pump cut-in. If not, continue adjusting pressure switch.

REPLACING GALVANIZED OR EPOXY LINED TANKS WITH WELL-X-TROL®

Many times a defective steel tank must be replaced with a WELL-X-TROL® to provide Effective System Protection, (ESP).

It is a simple procedure and the line drawing should be followed for correct connection to the system. Because the WELL-X-TROL® is precharged with air, it will always occupy less space for equal amounts of pressurized water than a galvanized or epoxy lined steel tank.

It is required that a relief valve be installed at the WELL-X-TROL® connection to ensure system protection.

Also BE SURE to plug the air port on a jet pump, as air is no longer required to be supplied to the tank.

RECOMMENDED PIPE SIZE FOR PUMP FLOWS

| PIPE SIZE | FLOW GPM |
|-----------|----------|
| 3/4 | 10 |
| 1 | 16 |
| 1 1/4 | 30 |
| 1 1/2 | 40 |

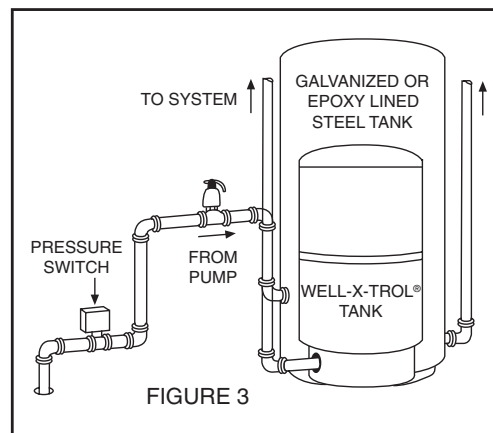
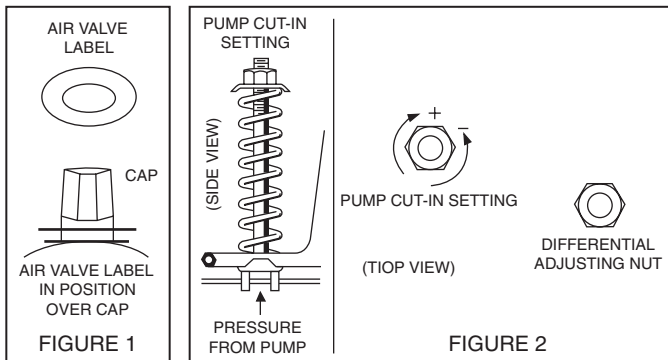

Location

The WELL-X-TROL® tank will operate anywhere in the system. Although where you put it will depend on its application and function.

1. Adjacent to pump. This is the location chosen most often. The WELL-X-TROL® can be used whether pumps are above or below the surface. In either case, it protects the pump by reducing surge, dampening pressure spikes, offering a point of pressure control, and providing minimum run time. This location also permits all equipment to be placed in an area that's both serviceable and secure.
2. At the end of long pipe runs. Sometimes, it's better to put the WELL-X-TROL® at the end of a long run of pipe, so it can provide rapid system response and adequate protection. When this location is chosen, the pressure switch should either be relocated with the WELL-X-TROL® or the setting should be adjusted to compensate for any line pressure drop.
3. Adjacent to shock creating components. If you want to use the WELL-X-TROL® to control shock or pressure fluctuations, then you should locate the tank as close to the cause as possible. This should be done when and where you have back flow preventors, check valves, solenoid, mixing and meter valves, pumps and other system controls which can contribute to system shock. **Caution:** Do not use for shock with flow velocities greater than 10 FPS.

System Connection

The connecting pipe between WELL-X-TROL® and the system should be as short as possible with a minimum of bends. It should also be as large in diameter as possible, consistent with system piping. You should never bush down from the WELL-X-TROL® (Figure A).

System Support

The surface which supports the WELL-X-TROL® should be capable of supporting its operating weight (including the weight of water).

Air Pressure - High Pressure Application

Check the air precharge pressure before any water enters the tank. The air valve is protected by a 1 1/2" coupling and plug. You'll find it located on the top of the tank. This pressure should be adjusted to 2 psig under pump cut-in pressure. In a surge or accumulator application, the charge should be 10% less than the line pressure.

Important: If increasing pre-charge above 55 psig, the following steps must be followed:

- a. Tank must be connected to the system with isolation valve open.
- b. System must be pressurized to 25-30 psig, matching the pre-charge setting of the tank.
- c. Isolation valve then needs to be closed.
- d. The pre-charge pressure of the tank can now be increased to the recommended high-pressure setting.
- e. Bring system up to pressure and then open the isolation valve to the tank.

Failure to follow these instructions could result in damage to the bladder or diaphragm and void all warranties.

Remember to replace and seal the plug after you've reached the correct air charge (it's a good way to tell if anyone has been tampering with the system).

Pressure Switch

For the best performance, you should put the pressure switch at or near the WELL-X-TROL® where pressure variations will be dampened. When you tune the system, you should adjust switch controls instead of the WELL-X-TROL® precharge.

Safety Protection

All installations should be according to prevailing codes and standards. In addition, you should protect the system by installing an adequately sized relief valve at or near the pump discharge. You should also provide facilities to drain the system.

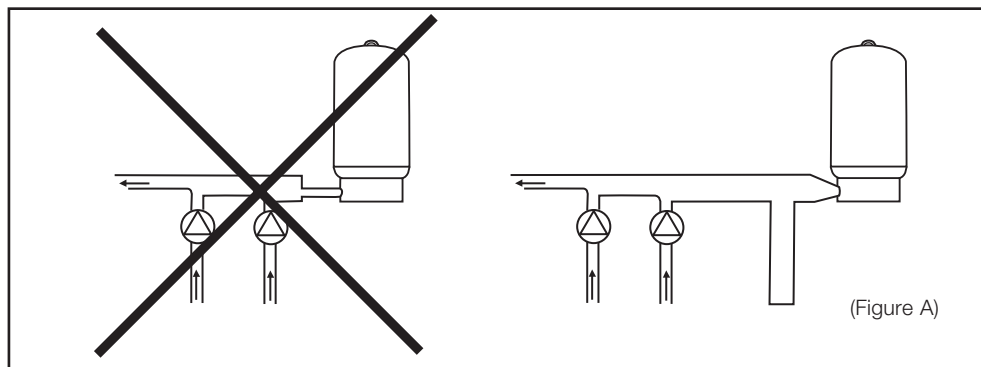

Typical Applications

1. In the sprinkler system for a golf course, two WELL-X-TROL®s are used. The larger 450 Series protects and assures proper pump operation. While the smaller 400 Series protects 'dead end' lines from hammer and surge.

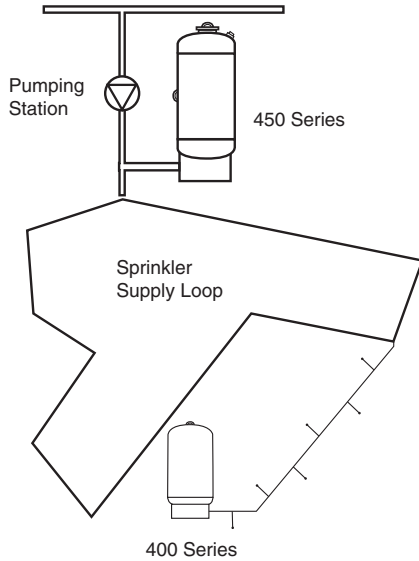

3. In a municipal well system or pressure boosting station, WELL-X-TROL®s are used to control sequential start of the main pumps. At the same time, it reduces surge and provides the jockey pump with guaranteed minimum run times during low peak demand periods.

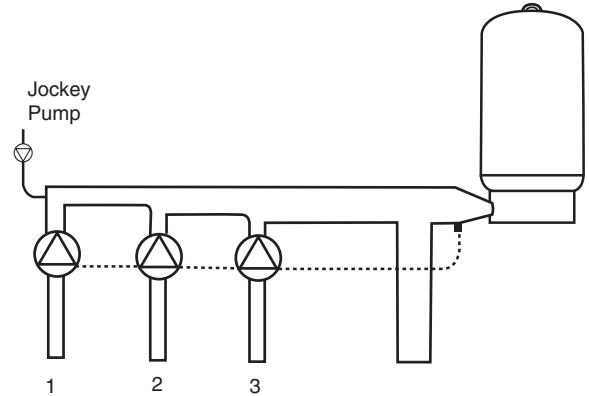

2. WELL-X-TROL® 450 Series are sometimes used on pressure regulation stations to provide system dampening during periodic high peak loading such as laundry wheels, etc.

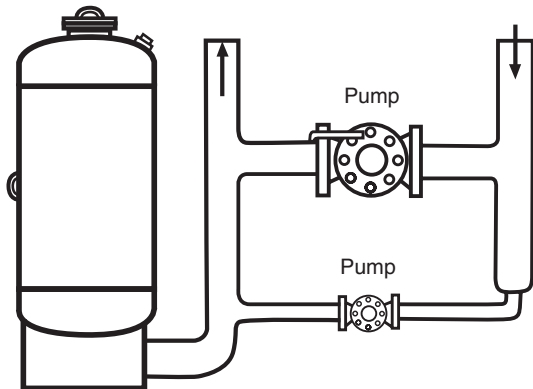

4. WELL-X-TROL® 400 Series are also used for high pressure booster applications, e.g. high rise buildings, irrigation systems and community wells.

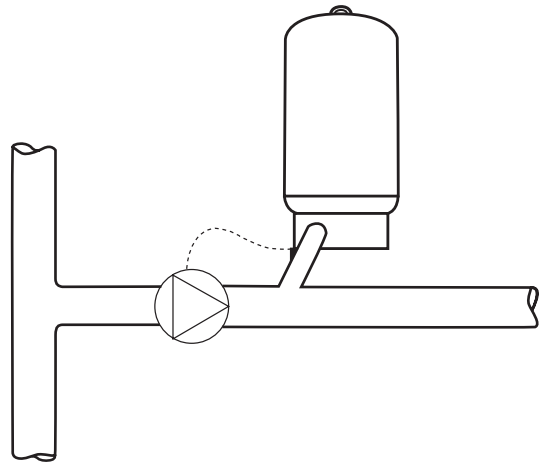

AMTROL INC. LIMITED PRODUCT WARRANTY

Products covered: all Products manufactured by AMTROL Inc. ("AMTROL").

This warranty cannot be transferred – it is extended only to the original Purchaser or First User of the Product. By accepting and keeping this Product you agree to all of the warranty terms and limitations of liability described below.

IMPORTANT WARNING – READ CAREFULLY THE INSTALLATION, OPERATING AND MAINTENANCE INSTRUCTIONS MANUAL ("MANUAL") to avoid serious personal injury and/or property damage and to ensure safe use and proper care of this product.

Who Receives AMTROL's Product Warranty

All purchasers or first users of the new Product. The Warranty is non-transferable.

What is covered by this Warranty

AMTROL warrants to the purchaser or first user of the new Product that at the time of manufacture, the Product is free from defects in material and workmanship. **Any warranty claim must be made within one (1) year unless another time period is set forth in the Manual, measured from the time the Product was purchased.**

What AMTROL Will Do If You Have a Covered Warranty Claim

In the event of a breach of the foregoing warranty, AMTROL will at its option either make repairs to correct any defect in material or workmanship or supply and ship either new or used replacement parts or products. AMTROL will not accept any claims for labor or other costs.

What This Warranty Does Not Cover – Exclusions and Limitations

This Warranty does not cover any failure or problem unless it was caused by a defect in material or workmanship. In addition, this Warranty shall not apply:

- if the Product is not correctly installed, operated, repaired or maintained as described in the Manual provided with the Product;
- to any failure or malfunction resulting from abuse (including freezing); improper or negligent: handling, shipping (by anyone other than AMTROL), storage, use, operation, accident; or alteration, lightning, flood or any other environmental condition;
- to any failure or problem resulting from the use of the Product for any purpose other than those specified in the accompanying Manual or alteration of any part of the product;
- if the Product is used anywhere except the United States, its territories or possessions, or Canada;
- this Warranty does not cover labor costs, shipping charges, service charges, delivery expenses, administrative fees or any costs incurred in removing or reinstalling the Product;
- this Warranty does not cover any claims submitted to AMTROL or an AMTROL-authorized distributor or retailer more than 30 days after expiration of the applicable warranty time period described in this Warranty;
- this Warranty also does not cover repair or replacement costs not authorized in advance by AMTROL.

Additional Warranty Limitations

ALL IMPLIED WARRANTIES, INCLUDING THE IMPLIED WARRANTIES OF MERCHANTABILITY AND FITNESS FOR A PARTICULAR PURPOSE ARE SPECIFICALLY DISCLAIMED. Some states do not allow limitations on how long an implied Warranty lasts, so the above limitation may not apply to you.

Limitations of Remedies

THE REMEDIES CONTAINED IN THIS WARRANTY ARE THE PURCHASER'S OR FIRST USER'S EXCLUSIVE REMEDIES. IN NO CIRCUMSTANCES WILL AMTROL BE LIABLE FOR MORE THAN, AND PURCHASER-FIRST USER'S REMEDIES SHALL NOT EXCEED, THE PRICE PAID FOR THE PRODUCT. IN NO CASE SHALL AMTROL BE LIABLE FOR ANY SPECIAL, INDIRECT, INCIDENTAL OR CONSEQUENTIAL DAMAGES, WHETHER RESULTING FROM NONDELIVERY OR FROM THE USE, MISUSE, OR INABILITY TO USE THE PRODUCT OR FROM DEFECTS IN THE PRODUCT OR FROM AMTROL'S OWN NEGLIGENCE OR OTHER TORT. This exclusion applies regardless of whether such damages are sought for breach of warranty, breach of contract, negligence, strict liability, in tort or under any other legal theory. Such damages include, but are not limited to, inconvenience, loss or damage to property, mold, loss of profits, loss of savings or revenue, loss of use of the Products or any associated equipment, facilities, buildings or services, downtime, and the claims of third parties including customers. Some states do not allow the exclusion or the limitation of incidental or consequential damages, so the above limitation or exclusion may not apply to you.

What To Do If You Have a Problem Covered By This Warranty

Any covered Warranty service must be authorized by AMTROL. Contact the person from whom you purchased the Product, who **must** receive authorization from an AMTROL distributor or AMTROL. If you do not receive a prompt response, call AMTROL directly at 877-517-9673. Notice of a Warranty claim should be submitted by the authorized distributor to AMTROL at the following address:

AMTROL Inc.
Warranty Claim Dept.
1400 Division Rd.
West Warwick, RI 02893

Before AMTROL determines to provide any replacement part or Product, it may as a pre-condition to making such a determination require that the warranty claimant ship the Product, postage prepaid to an authorized AMTROL distributor, or to AMTROL and provide proof of purchase evidenced by the original sales receipt or Product registration.

Replacement Product Warranty

In case of replacement of a Product or any component part, AMTROL reserves the right to make changes in the design, construction, or material of the substitute components or products, which shall be subject to all of the terms and limitations of this Warranty, except that the applicable warranty periods shall be reduced by the amount of time the warranty claimant owned the product prior to submitting notification of the warranty claim.



In the interest of continuous development, AMTROL Inc. and its subsidiaries reserve the right to alter designs and specifications without prior notice. The AMTROL logo, AMTROL and Well-X-Trol are registered trademarks of AMTROL Inc. and its affiliates. All rights reserved.