

HYDROMATIC®

ENGINEERED PRODUCTS

DRY PIT

Non-Clog Dry Pit Pumps

- Wastewater
- Lift Stations
- Treatment Plants
- Sump
- Drainage
- De-watering
- Sludge and Slurry
- Industrial Waste



Hydromatic® Non-Clog Dry Pit Pumps

FEATURES

Dependability

The Hydromatic pumps oil-filled motor keeps the windings cool, eliminates moisture, and permanently lubricates the bearings, to provide reliable pumping service.



First, the oil bath keeps the motor and bearings cool by dissipating heat and maintaining the correct operating temperature. The oil transfers heat generated in the motor windings to the housing where it is dissipated.

Second, the oil bath locks out airborne moisture contamination which destroys motors and bearings. Air carries moisture that condenses with temperature changes and causes premature motor and bearing failure.

Third, the oil bath permanently lubricates the bearings which minimizes heat and flushes contaminants away from bearing races.

Heat and contaminants cause grease breakdown that leads to premature failure of grease-packed bearings supplied by other manufacturers. Oil-filled motors ensure dependable, reliable service!

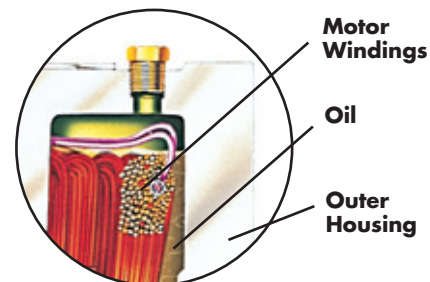

You get long pump life because the oil-filled motor dissipates heat from the windings, through the oil, to the outer housing.



Reliability

The moisture sensor saves money and decreases downtime by allowing you to take corrective action before an expensive bearing or motor failure occurs.

Hydromatic pumps incorporate an internal moisture sensor that detects the presence of moisture in the oil chamber.

The sensors signal to the warning system lets you know that the lower seal is beginning to leak. This allows you to schedule maintenance within 2 to 4 weeks while the pump continues to operate.

Some manufacturers put a moisture sensor in the motor area. Moisture is detected after it begins affecting the bearings and motor itself. The lower seal moisture sensor allows you to perform maintenance at your convenience instead of reacting to an emergency breakdown.

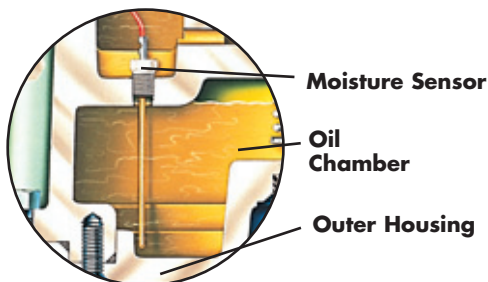

The internal moisture sensor saves you money and decreases downtime.

Hydromatic supplies necessary plumbing to connect the water jacket to the suction and discharge piping. This plumbing includes ball valves that allow easy removal of the water jacket for periodic cleaning without shutting down the system.



Hydromatic® Non-Clog Dry Pit Pumps

BENEFITS

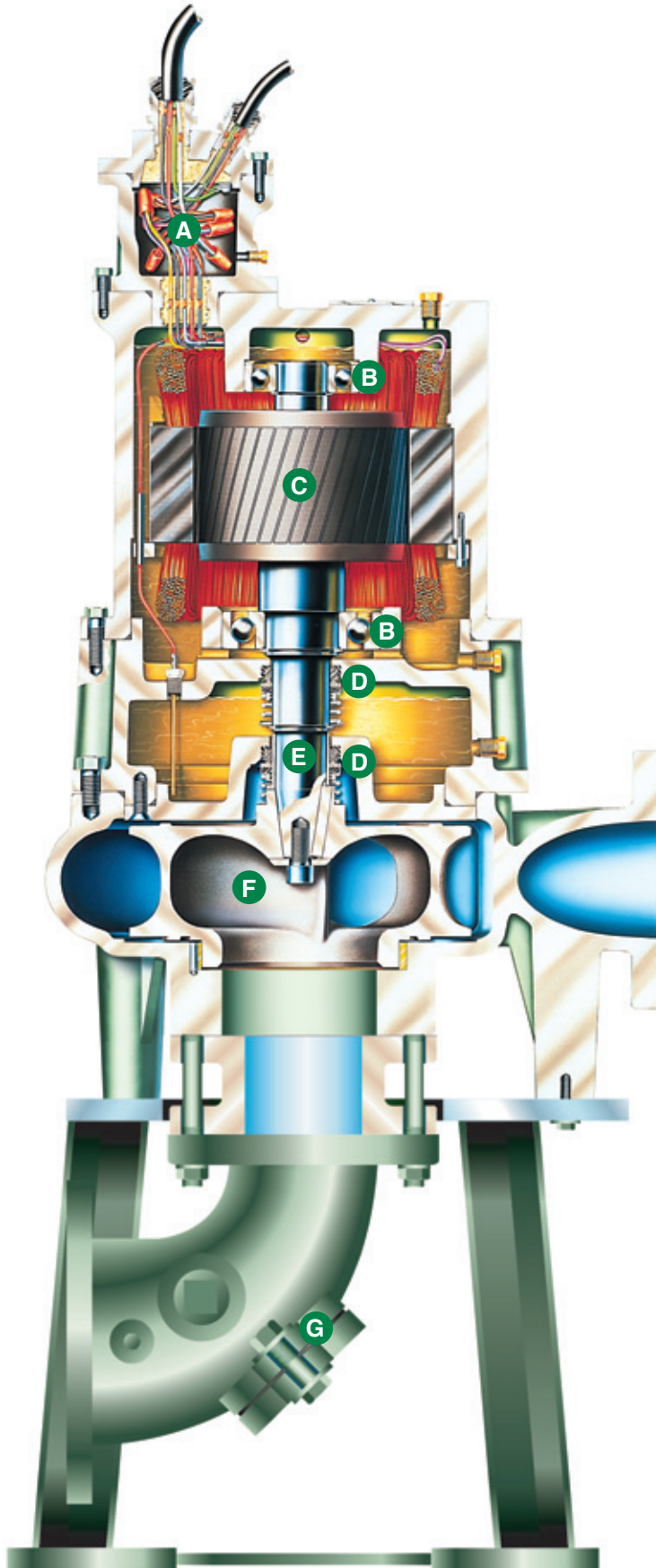

A. **Connection Box**

Two epoxy barriers and a compression fitting prevent water contamination of the motor area assuring long term reliable operation. Additionally, epoxy encapsulation and stripped leads positively eliminate “wicking” from the cable.

B. **Bearings**

Heavy-duty ball bearings, upper (radial) and lower (thrust), are submerged in oil to provide permanent lubrication and ensure long service life.

C. **Motor**

Hydromatic uses “Class H” Insulation for long life. Three phase pumps are suitable for use with VFD drives. Oil filled motor efficiently dissipates heat and locks out damaging moisture so you receive reliable pumping service.

D. **Seals**

Dual seal system operates in an oil chamber to provide long pump service life.

E. **Shaft**

The stainless steel shaft eliminates corrosion and fatigue to give longer pump life. The minimum shaft overhang decreases deflection and increases bearing and seal life.

F. **Impeller**

Two vane non-clog impellers provide the most energy efficient design. Pump-out vanes on the top shroud prevent the buildup of materials in the seal area and extend the life of the thrust bearing by significantly reducing axial thrust.

G. **Clean-Out**

The pump is provided with a clean-out type cast iron suction elbow which is bolted directly to the pump suction flange. A clean-out hole is provided with a removable cover of the largest possible size.



Efficiency

The electrical power costs chart compares Hydromatic pumps with three other pump manufacturers. For example, with a Hydromatic pump you save \$4,628 in one year of continuous operation compared with manufacturer "A". This more than pays for the pump!

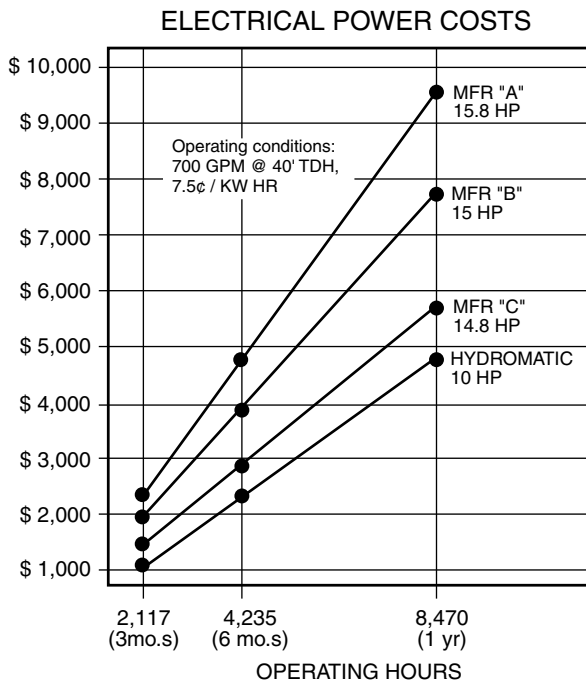

Low Maintenance

Hydromatic pumps are virtually maintenance free because the oil-filled design keeps the motor and bearings both fully lubricated and operating in the proper temperature range for very long life. You schedule and perform periodic maintenance for bearings and seals less often than required by other manufacturers.

Cooling Fins (Optional)

When additional cooling is required Hydromatic can supply pumps with cooling fins. These cooling fins are designed to keep the motor temperature in the normal operating range.



Water Jacket (Optional)

When additional cooling is required Hydromatic can supply pumps with water jackets. These water jackets are designed to keep the motor temperature in the normal operating range.



Hydromatic® Non-Clog Dry Pit Pumps

PERFORMANCE

1750 RPM

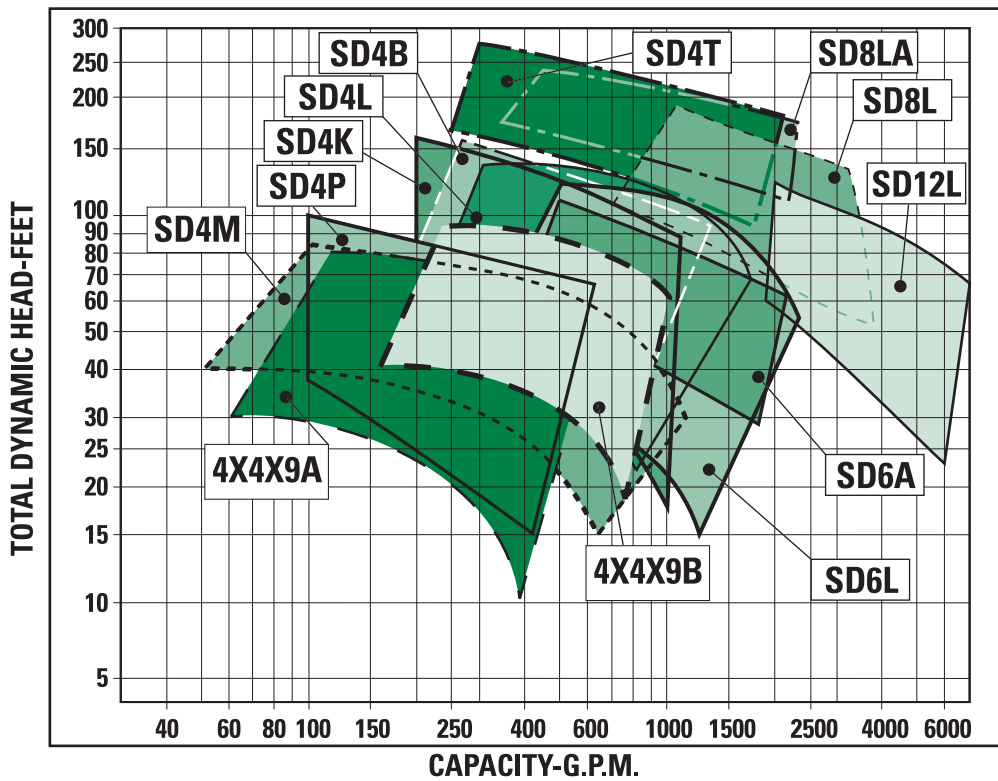

1150 RPM

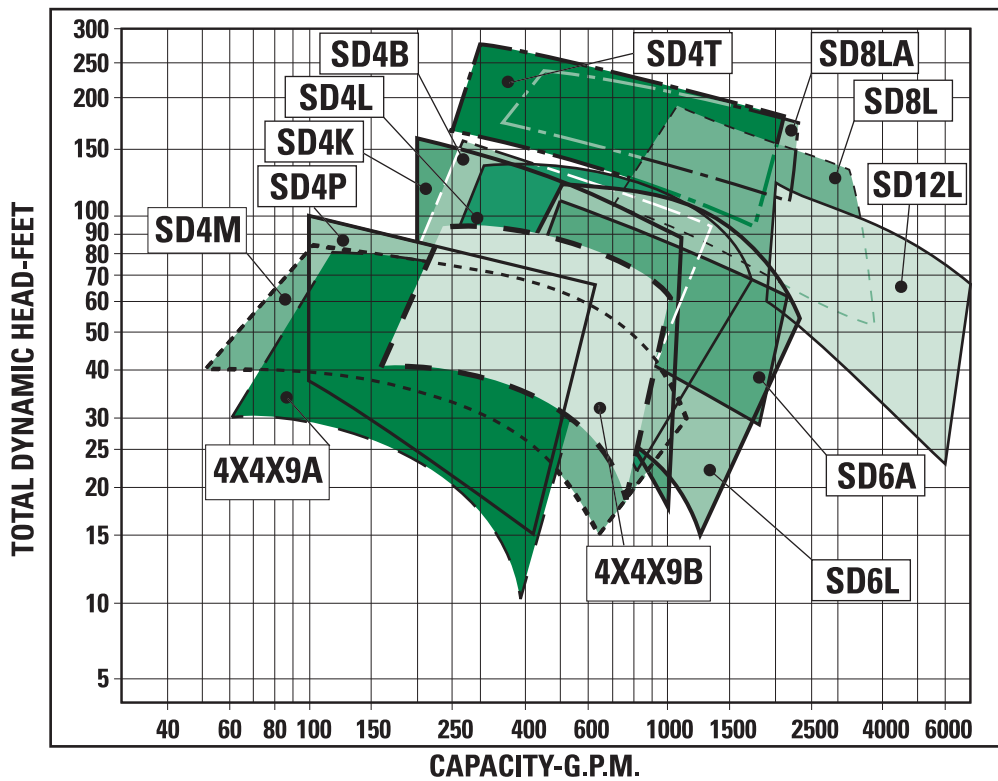

870 RPM

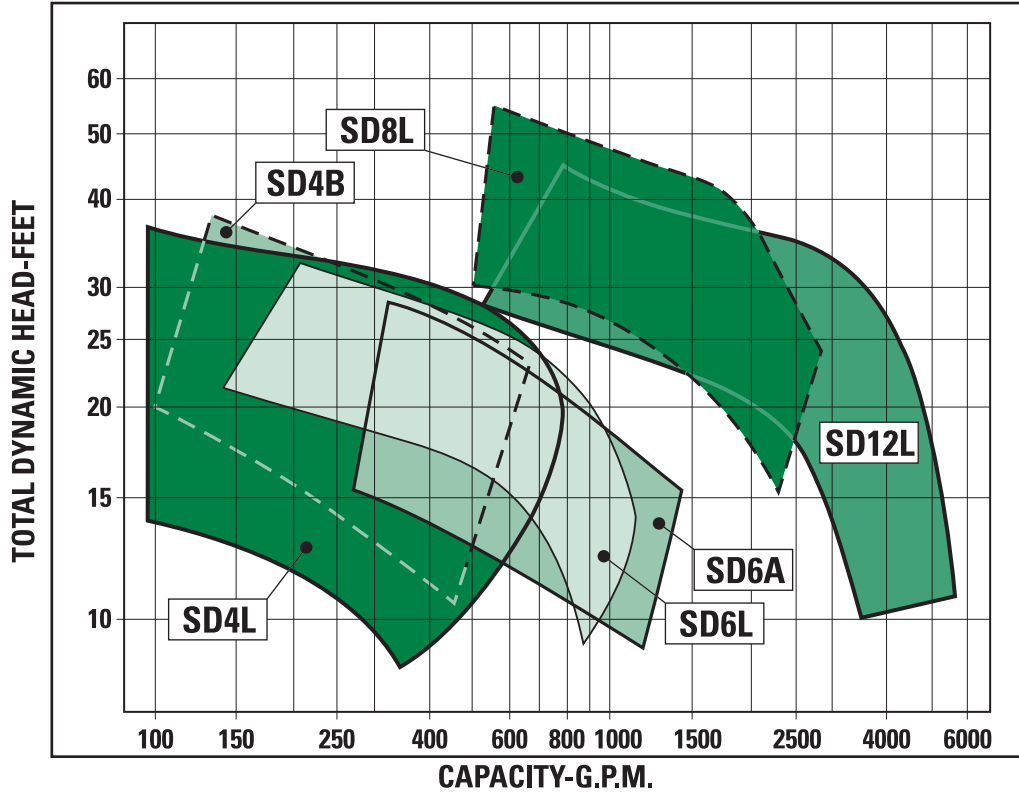

RANGE CHARTS FOR THE RECESSED IMPELLER

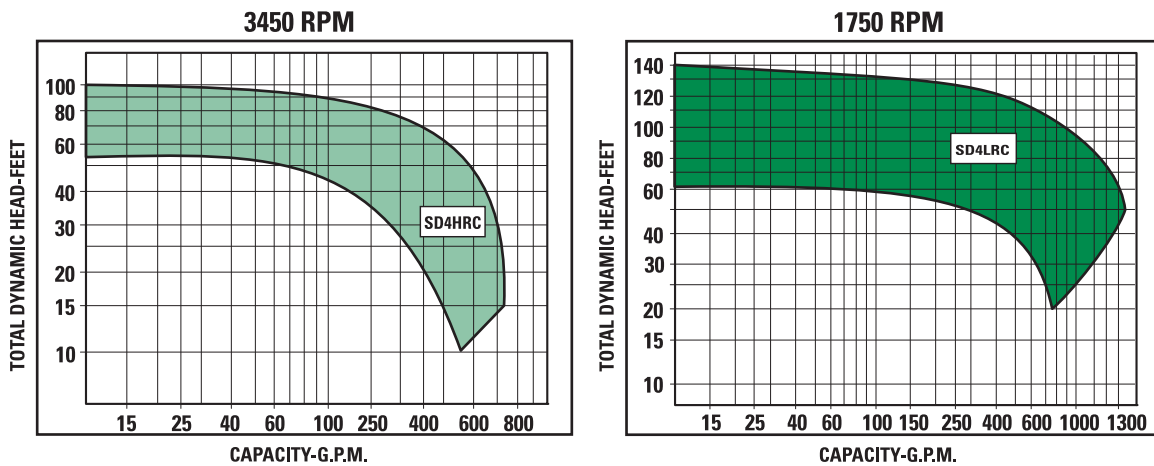

Hydromatic® Non-Clog Dry Pit Pumps

OVERVIEW

You can depend on Hydromatic pumps to provide years of reliable service. Currently, there are thousands of units operating trouble-free throughout the world. As one of the oldest pump manufacturers in the world, Hydromatic offers you field-proven pumps and systems for all your requirements. Hydromatic has a 5 year pro-rated warranty available. We also supply complete technical support, and ongoing engineering assistance for the life of the pump.

Installations:

• **Municipal**

- Wastewater transfer
- Wastewater treatment plants
- Wastewater lift stations
- Subdivisions
- Airports
- Storm water

• **Commercial**

- Building wastewater systems
- Wastewater
- Hospitals
- Motels
- Apartments
- Schools
- Churches
- Universities
- Campgrounds
- Amusement Parks

• **Industrial**

- Wastewater
- Sump
- Spray wash

Benefits:

- **Field-proven**
- **Reliable, long life equipment**
- **Quick delivery**
- **Easy-to-install**
- **Low operating costs**
- **Completely field serviceable**
- **Easy-to-service**
- **Energy efficient**
- **Less maintenance**



HYDRAMATIC®
ENGINEERED PRODUCTS
USA

740 E. 9th Street Ashland, Ohio 44805
Tel: 419-289-3042 Fax: 419-281-4087

www.hydraulic.com

– Your Authorized Local Distributor –

CANADA

269 Trillium Drive Kitchener, Ontario, Canada N2G 4W5
Tel: 519-896-2163 Fax: 519-896-6337