



HYDROMATIC®

DRY PIT

Non-Clog Dry Pit Pumps

- Wastewater
- Lift Stations
- Treatment Plants
- Sump
- Drainage
- Dewatering
- Sludge and Slurry
- Industrial Waste

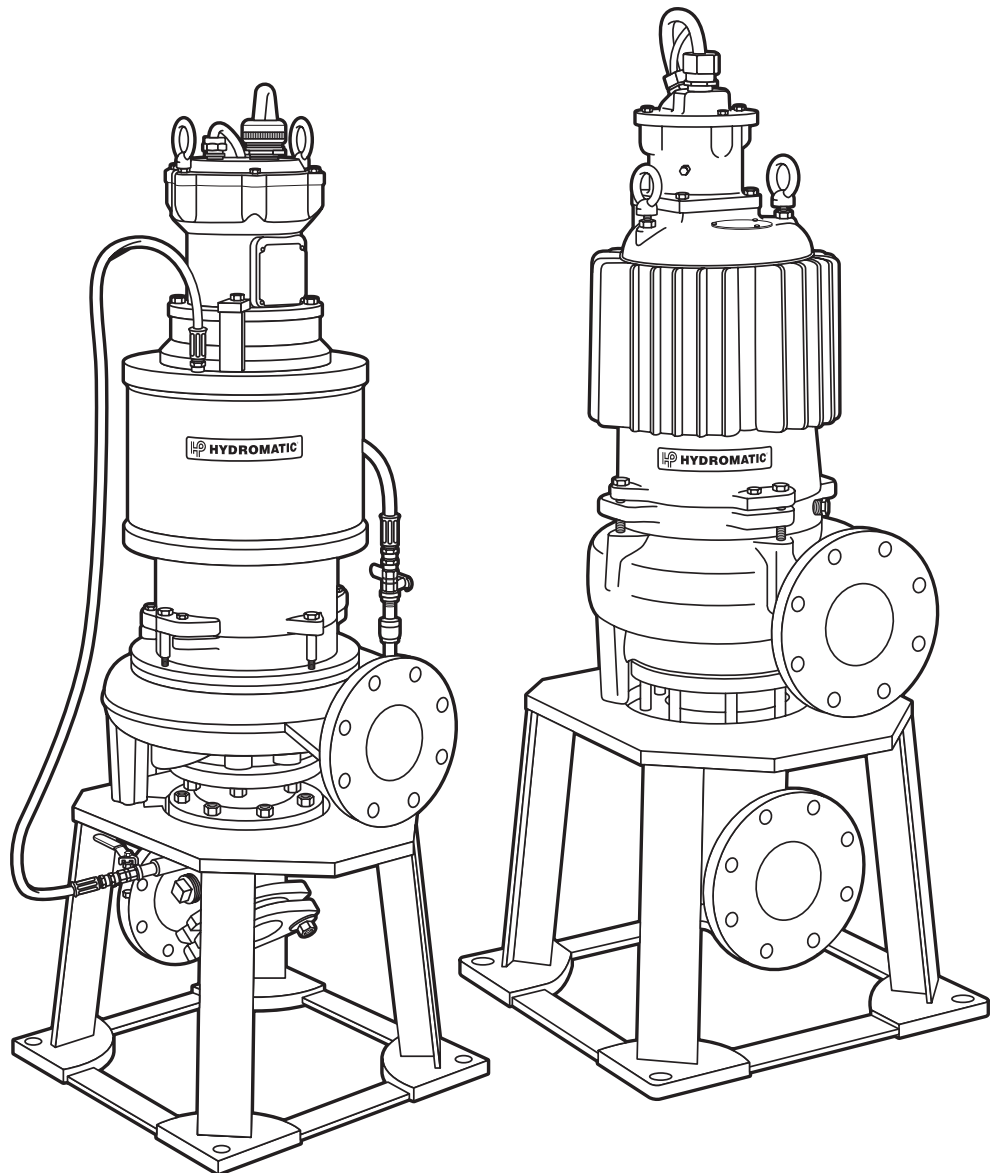

NOTE! To the installer: Please make sure you provide this manual to the owner of the pumping equipment or to the responsible party who maintains the system.



Pentair
Water™

General Information

SHIPPING

When unpacking unit, check for concealed damage. CLAIM FOR DAMAGE MUST BE MADE AT THE RECEIVING END THROUGH THE DELIVERING CARRIER. DAMAGE CANNOT BE PROCESSED FROM THE FACTORY.

PUMPS NOT OPERATING OR IN STORAGE

Pumps with carbon ceramic seals must have impellers manually rotated (6 revolutions) after setting nonoperational for 3 months or longer and prior to electrical start-up.

Pumps with carbide seals must have impellers manually rotated (6 revolutions) after setting nonoperational for 3 weeks or longer and prior to electrical start-up.

SEAL FAILURE

An electrode is installed in the seal chamber so if water enters the chamber through the first seal, the electrode will be energized and a signal will be transmitted to the sensing unit at ground surface, causing an alarm activation. The electrode probe is installed in all units, but the sensing unit is supplied at an extra cost and must be ordered.

In operation the seal failure unit indicates only that there is some water in the seal chamber. The pump will continue to operate without damage, but the seal should be checked immediately after failure is indicated.

The sensing unit is recommended on all installations as good insurance against motor failure.

PUMP

The dry pit submersible pump is supplied for 1 or 3 phase and for 200, 230, 460 or 575 volts. Pump is supplied with 30 feet of power cord and/or 30 feet of auxiliary control cord. Longer cable lengths can be furnished but must be specified at time of order. Be sure green wire is connected to a good ground such as water pipe or ground stake. The auxiliary cable for the seal failure and heat sensors is also 4 wire and color coded.

HEAT SENSORS

All motors have heat sensor units embedded in the motor winding to detect excessive heat. The heat sensors are set to trip at 120°C. The sensors automatically reset when the motor cools to safe temperature.

The sensors are connected in series with the motor starter coil so that the started is tripped if heat sensor opens. The motor starter is equipped with overload heaters so all normal overloads are protected by the starter.

IMPORTANT

If Hydromatic® electrical starting equipment is not supplied, the heat sensor circuit must be connected in series with the started coil or warranty on the motor is void. Connection diagram is included in the manual.

WET WELL LEVEL CONTROL

Sump level is controlled by Hydromatic switch controls. The float is held in position in the sump by a weight attached power cord above the float. The cord supports the float and is adjusted for height from the surface.

Duplex systems use three controls: one set at turn-off, one set at turn-on for one pump, and one set at turn-on for both pumps. Pumps then alternate lead and lag on each successive cycle. Two pumps operate together only when the sump level rises to the third or override control. The override control also brings on the second pump in case of failure of the first pump. Extra floats with appropriate controls can be supplied for alarm functions. Triplex systems use four controls: One set at turn-off, one set at turn-on for one pump, one set at turn-on for two pumps, and one set at turn-on for three pumps. The pumps alternate with each successive cycle.

Three pumps operate together only if the sump level rises to the fourth control (second override). This control also brings on the third pump in case of failure of either or both of the first two pumps.

ALARM CONTROLS

The alarm level is usually set above the override level so the alarm will signal only if the override level is exceeded. However, some engineers prefer to have the alarm level set below the override level as it is possible for one pump to fail and the other pump to operate on the override level with the sump level never reaching the alarm level. This is particularly true in cases of low inflow capacity.

ELECTRICAL CONTROL PANEL

It is recommended that the Hydromatic control panel be used with all pumps as proper starter heaters and connections for heat sensor wires are furnished.

IMPORTANT

If Hydromatic electrical controls are not used and the motor fails because of improper components or if the heat sensors are not properly connected, the motor guarantee is void.

Hydromatic electrical equipment is installed in a weatherproof NEMA 3R enclosure. The electrical equipment includes a main circuit breaker for each pump, a magnetic starter with overload protection for each pump, an H-O-A switch and a run light for each pump, an electrical alternator and a transformer to provide appropriate control for control circuit and alarms.

OVERLOAD HEATERS

Starters with 3 leg overload protection must be supplied if the Hydromatic electrical panel is not used. The heaters must be sized in accordance with the nameplate amps on the motor. The amp draw on these oil filled motors is slightly higher than a corresponding horsepower surface motor, so heaters must be sized by the nameplate rating.

Installation Instructions

INSTALLING PUMP IN DRY PIT

Before installing pump in the dry pit, lay it on side and turn the impeller manually. The impeller may be slightly stuck due to factory water testing, so it must be broken loose with a small bar or screwdriver in the edge of the vanes. The impeller must turn freely.

Clean all trash and debris from pump installation area and connect pump to plumbing.

A check valve must be installed on each pump. A gate or plug valve in each pump discharge line is also recommended. This valve should be installed on the discharge side of the check valve so the line pressure can be cut off to service the check valve. Single pump systems are sometimes installed without a check valve where it is desirable to self drain the discharge line to prevent freezing. This can be done only with short discharge lines. Otherwise water will return to the sump and cause short cycling of the pump.

MOUNTING PUMP STAND

The pump will ship from the factory on a dry pit pump stand. The suction and discharge of the pump will be oriented at the factory per the prescribed customer order.

The dry pit pump must be anchored to the pump station floor. This must be done to alleviate stress on the suction and discharge piping while the pump is in service. When securing the pump stand to the contractor supplied anchor bolts, it may be necessary to shim the stand to ensure the suction and discharge piping properly aligns.

PLUMBING (GENERAL)

The site contractor must supply the use of necessary pipe hangers or other piping supports. Both the suction and discharge piping must be independently supported and properly aligned to ensure no strain is transmitted to the pump when connections are tightened. The use of expansion joints or vibration pads does not preclude the need to properly support the piping.

NOTE: DO NOT SUPPORT THE PIPING BY THE PUMP.

DO NOT FORCE PIPING WHEN MAKING CONNECTIONS.

SUCTION-INLET PIPING

The correct sizing and installation of the suction plumbing is particularly important. The suction piping must be selected and installed in such a manner that it minimizes pressure losses and allows for sufficient flow during starting and operation. Most NPSH problems can be traced directly to improper design of suction piping systems.

It is recommended that the piping be as direct as possible and the length should be at least 10 times the diameter of the pipe. When a pipe diameter larger than the suction of the pump is used, an eccentric reducer should be used with the eccentric side down. This will allow for the elimination of a potential air pocket in the suction plumbing.

NOTE: A PIPE DIAMETER SMALLER THAN THE SUCTION OF THE PUMP MUST NEVER BE USED.

It is also recommended that a valve be installed in the suction piping to isolate the pump during routine maintenance and shutdown. A globe valve should not be used when NPSH is critical.

It is recommended that a compound pressure gauge be installed in the suction piping to assist in troubleshooting potential performance problems.

DISCHARGE-OUTLET PIPING

The discharge piping for short runs can be of the same size as the discharge of the pump. It is recommended that longer runs be 1 to 2 sizes larger depending on the length. Any elevated points will retain air pockets, and it is recommended that air vents or bleed lines be installed at these points to evacuate entrapped air. Installation of a valve near the

WIRE SIZE AND MAXIMUM LENGTH (FEET) FOR REMOTE LOCATION OF CONTROL PANEL BASED ON A 2% VOLTAGE DROP (230 VOLTS 3 PHASE)

Copper Wire		Amperes @ 230 Volts*																	
No. AWG	D.C. Res. /M Ft.	5	10	15	20	25	30	40	50	60	70	80	90	100	120	140	160	180	200
12	1.620	325	165	110	80	65	55												
10	1.018	520	260	175	130	105	85	65											
8	0.6404	830	415	275	205	165	140	105	80										
6	0.410	1295	645	430	320	260	215	160	130	105	90	80							
4	0.259		1025	680	510	410	340	255	205	170	145	130	115	100	85				
**3	0.205		1295	865	650	520	430	325	260	215	185	160	145	130	110	90			
2	0.162			1090	820	655	545	410	340	295	255	230	205	180	160	135	110	100	
1	0.129				1030	825	685	515	410	340	295	255	230	205	170	145	130	115	
0	0.102					1040	865	650	520	435	370	325	290	260	215	185	160	145	130
00	0.081						1090	820	655	545	470	410	365	325	270	235	205	180	165
000	0.064							1035	825	690	590	515	460	415	345	295	260	230	205

Note: For 460 volts obtain distance by multiplying by 2.0.

For 575 volts obtain distance by multiplying by 2.5.

* 230 volt system not recommended for above 30 to 40 horsepower.

** Special junction box required for wire sizes larger than #4.

*** Based on 3 power conductors in cable conduit, 4 to 6 reduce ampacity to 80% & for 7 to 24 reduce to 70%.

***60°C

***Rating 90°C

Insulation @ 30°C Amb.

NUMBER OF CONDUCTORS REQUIRED BETWEEN CONTROL PANEL AND NEMA 4 JUNCTION BOX

Power lines and control wires can be carried in conduit or underground buried cable.

System Type	Number of Control Wires	Number of Power Lines	Number of Ground Wires #8	HEAT SENSOR & SEAL FAILURE	
				Number of Sensor Wires	Number of Ground Wires
Simplex	3	3	1	3	1
Simplex with Alarm	5	3	1	3	1
Duplex	5	6	1	6	2
Duplex with Alarm	7	6	1	6	2

discharge of the pump is recommended to isolate the pump during maintenance and shutdown.

It is recommended that a pressure gauge be installed near the discharge of the pump to assist in troubleshooting potential performance problems.

NEMA 4 JUNCTION BOX (OPTIONAL)

A NEMA 4 junction box should be used to make power and control connections if electrical control panel is to be set remote from the

pump station. The Hydromatic NEMA 4 junction box is provided with compression connections for sealing all wires. No sealing compound is needed to make connections waterproof.

Wiring diagrams are provided with the panel for making connections. An extra set of diagrams is included so that one set can be used in the station when making connections. The size wire to use from panel to station depends on motor size and distance in feet.

The wire size table on Page 4 can be used as a guideline for wire size. Be sure each wire is checked out so that a wrong connection will not be made. An ohmmeter or Megger can be used to check the continuity. Attach one side of meter to ground and the other side to one side of the control panel. Then have a person in the station touch the wire to ground. If the wire is correct, meter will show reading. A handheld radio may be useful if some distance exists between station and panel.

INSTALLING SWITCH CONTROLS

The controls are supported by a mounting bracket that is attached to wet well wall, cover or to the NEMA 4 junction box. Cord snubbers are used to hold the cord in place. Control level can be changed at any time by loosening the snubber and readjusting cord length.

In either a simplex or duplex system, the lower or turn-off control is set just above the drywell inlet. This is dependent on the inlet velocity of the pump. The second or turn-on control is set at least 24 inches above the lower turn-off control.

More distance between turn-on and turn-off controls can be used, but sewage may become septic, and excessive solids may collect for the pump to handle. A frequent pumping cycle is recommended for best operation.

If an alarm system is used, this control is usually set about 6 inches above the override control.

Some engineers, as described previously, prefer to have the alarm control set below the override control.

MAKING ELECTRICAL CONNECTIONS

All electrical wiring must be in accordance with local codes, and only certified electricians should make the installations. Complete wiring diagrams are adhered to the inside cover of the panel, and an additional set of prints is included for use in making the installation. All wires should be checked for ground with an ohmmeter or Megger after the connections are made. **THIS IS IMPORTANT AS ONE GROUNDED WIRE CAN CAUSE CONSIDERABLE TROUBLE.**

IMPORTANT

If equipment is not properly wired and protected as recommended, the motor guarantee is void.

208-230V SINGLE PHASE

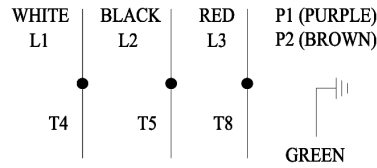

208 & 575V THREE PHASE

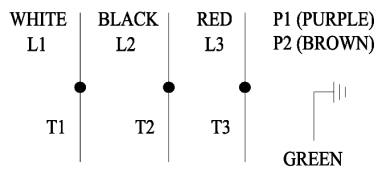

230V (DUAL VOLTAGE) THREE PHASE

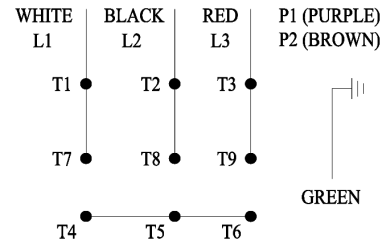

460V (DUAL VOLTAGE) THREE PHASE

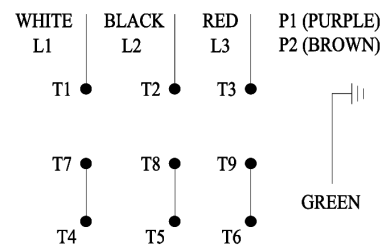

HEAT SENSORS AND SEAL FAILURE CONNECTIONS

Be sure heat sensor wires are connected in series with the starter coil. Connections are provided on the terminal strip (see wiring diagram).

If seal failure unit is used, connect as shown with seal failure system. If seal failure unit is not used, the two seal failure wires are left open.

DO NOT CONNECT POWER TO THESE LINES AT ANY TIME.

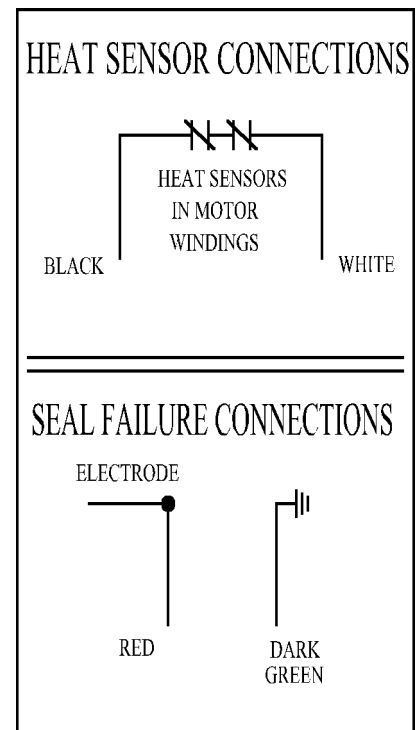

COOLING FINS (OPTIONAL)

When additional cooling is required, cooling fins are permanently adhered to the motor housing at the factory. Inspect the cooling fins to ensure that they are intact and not damaged prior to plumbing the pump in the system.

NOTE: The cooling fins must be intact to ensure the pump operates within the factory specified temperature.

WATER JACKET (OPTIONAL)

When additional cooling is necessary, a water jacket is supplied from the factory. All necessary plumbing of the water jacket is supplied from the factory connecting to the suction and the discharge piping. The plumbing includes ball valves allowing for removal of the water jacket for periodic cleaning without shutting the system down.

The water jacket is held in place by clamps and is sealed both top and bottom by O-rings. Upon removal of the water jacket for cleaning care should be taken not to damage the O-rings and replace if necessary.

NOTE: Clean fresh water supplied to the water jacket will reduce the necessity of frequent periodic cleaning of the water jacket. This does not preclude that the water jacket should not periodically be cleaned.

Pump Operation

STARTING SYSTEM

1. Turn H-O-A switch to Off position and then turn on main circuit breakers.
2. Open all discharge valves and allow water to rise in wet well.
3. Turn H-O-A switch to Hand position on one pump and notice operation. If pump is noisy and vibrates, rotation is wrong. To change rotation, interchange any two line leads to a three phase motor only. **DO NOT INTERCHANGE MAIN INCOMING LINES.** If duplex system, check second pump in the same manner.

4. Now set H-O-A switch to Auto position and allow water to rise in the wet well until the pump starts. Allow pump to operate until level drops to turn-off point.
5. Allow wet well level to rise to start the other pump. Notice run lights on the panel. Pumps should alternate on each successive cycle of operation.
6. Turn both H-O-A switches to Off position and allow wet well to fill to the override control level.
7. Turn both switches to Auto position and both pumps should start and operate together until level drops to turn-off point.
8. Repeat this operation cycle several times before leaving job site.
9. Check voltage when pumps are operating and check amp draw of each pump. Checks amps on each wire, as sometimes a high leg will exist. One leg can be somewhat higher (5 to 10%) without causing trouble. For excessive amp draw on one leg, the power company should be consulted.

PHASE CONVERTERS

Phase converters are generally not recommended, but in cases where only single phase current is available, phase converters can be used. Be sure to size the phase converter large enough for the amp draw specified on the motor nameplate, not necessarily by motor horsepower. The warranty of all three phase submersible motors is void if operated with single phase power through a phase converter and 3 leg ambient compensated extra-quick trip overload protectors are not used.

Pump Maintenance

Lubrication or other maintenance is not required, as the motors are oil filled.

If a seal failure unit is used, no attention is necessary as long as the seal shows satisfactory operation.

If seal failure is not used, the pump should have the oil drained from the seal chamber once every two years and inspected for water.

Generally, these pumps give very reliable service, and can be expected to operate for many years without failure under normal operating conditions.

LIGHTNING

In some areas where considerable lightning occurs, we recommend that a lightning arrestor be installed at the control panel. Lightning arrestors are good insurance against damage to an expensive motor.

SERVICING INSTRUCTIONS

Important: Read all instructions prior to replacing any parts.

Warning: Before handling these pumps and controls, always isolate and disconnect power first.

Do not smoke or use any sparkable electrical devices or flames in a septic (gaseous) or possible septic environment.

FIELD SERVICE ON MOTOR

All dry pit pump motors can be serviced (out of warranty) in the field by any reliable motor service shop. Any pump (in warranty) must be returned to the factory for service or repaired in an authorized Hydromatic service center. Charges will not be allowed if (in warranty) pump is taken to a motor repair shop that is not an authorized Hydromatic service center.

When field service is performed on a pump, these instructions should be carefully followed.

REPLACING STATOR

If motor winding is burned or shorted it can be rewound or replaced with a new factory wound stator. Refer to the sectional drawing of the pump and motor and then use the following steps to remove and replace the stator.

1. Un-plumb and drain water jacket if pump was supplied with a water jacket and remove.
2. If stator only is damaged it may not be necessary to completely dismantle pump as stator and housing can be lifted from pump without disturbing seals or bearings.
3. Drain all oil from upper housing, remove drain plug in bottom of stator housing and remove plug in top of housing to allow air to enter.
4. After chamber is drained, remove hold-down bolts and lift off. Use care in lifting as the seal failure connecting wires must be disconnected before housing is completely removed. See sectional drawing.
5. Set assembly on bench and remove connection box. When box is lifted off, connection wires to motor will be exposed. These wires will probably be

burned, but each wire will be identified with a metal wire marking number. Cut the wires.

If the leads in the connection box are burned, a complete new connection box with new wires must be used. The wires are potted in with sealing compound and a new unit must be obtained from the factory.

6. The stator is held in the housing with a bolted-in clamp ring.
7. After ring is removed, turn housing upright and bump on hardwood blocks. This should jar the stator loose and allow it to drop out.
8. Thoroughly clean housing before replacing new stator. Replace stator and make all wire connections to connection box before replacing housing on pump. This is important as leads must be tucked behind the windings by using hands up through rotor core.

IMPORTANT: Use only compression type insulated connectors on the wires.

Do not tape leads as oil will deteriorate the tape and cause damage to stator and bearings.

9. Drain oil from lower seal chamber. If oil is clean and no water is present, seals can be considered satisfactory to reuse.
10. Check top bearing. If clean and does not turn rough, bearings can be reused and it is not necessary to completely dismantle pump and change bearings. If bearings are damaged with dirt or heat they must be replaced. See additional instructions on replacing seals and bearings. Remember to reinstall the upper bearing load spring.

11. Replace stator housing onto seal chamber and bolt in place. **BE SURE SEAL FAILURE WIRE IS CONNECTED BEFORE HOUSING IS ASSEMBLED.**

Be sure O-ring seal has been replaced. If O-ring appears nicked or cut, replace with new ones. This applies to O-rings in the assembly.

12. After all leads are reconnected in the connection box, make a high voltage ground test on each wire. The only wire that should show ground is the green power lead and the ground lead in the auxiliary power cable.
13. For safety, complete pump should be air checked under water for leaks. If seals are OK, refill seal chamber with oil. Lay pump on side for this oil filling with oil fill hole upright. Do not completely fill; leave oil about 1 inch below plug hole. Use only Hydromatic submersible oil in this chamber or high grade transformer oil. Replace plug; use Permatex on threads. Install air valve in top plug opening of motor housing and charge housing with about 10 psi of air. Be sure air is dry. Do not use air line where water may be trapped in the line. Submerge complete unit under water and check for leaks.
14. Refill motor chamber with oil. Use only a high grade transformer oil or Hydromatic special submersible oil. Fill chamber until oil covers top of windings. Leave air space in top for expansion. Use Permatex on plug threads.

REPLACING SEALS AND BEARINGS

1. Drain all oil from motor chamber and seal chamber as described.
2. Remove motor housing as described.
3. Remove bolts that hold seal chamber to pump housing. Use back-off screws to break loose.
4. Lift rotating assembly (rotor, shaft, and impeller) from pump case and place horizontally on bench.
5. Remove the impeller by holding the rotor and removing the impeller retaining washer and bolt. The impeller will be taper fitted to the shaft with a key. The impeller may need to be jarred from the shaft by tapping with a block of wood.
6. A shaft sleeve may be used in conjunction with the lower seal and will need to be removed.
7. Remove lower seal spring and pry out the seal with a screwdriver.
8. To remove the seal housing, take out socket head bolts and using the bolts in the back-out holes, pry plate loose. This will force out lower seal if not already removed.
9. Remove snap ring that holds upper seal. Pull seal if it is free. If not free, it can be forced off when shaft is removed.
10. Remove 4 bolts that hold bearing housing in place. Set assembly in upright position and bump end of shaft with hardwood block. This will push the bearing from the housing and will force upper seal from shaft.
11. Use a bearing puller to remove bearings. Replace with new

bearings. Press only on inner face of bearing when replacing. Pressing on the outer face can damage the bearing. Bearings are standard size that can be obtained from any bearing supply house or can be obtained from the factory.

12. **IMPORTANT: DO NOT USE ANY OF THE OLD SEAL PARTS. REPLACE WITH ALL NEW SEALS.**
13. Thoroughly clean all castings before replacing seals. Any dirt between the seal faces can cause failure.
14. Examine all O-rings for nicks before using and replace damaged O-rings with new ones.
15. Use Loctite on socket head impeller locking screw in end of shaft.

Pump Troubleshooting

Below is a list of common problems and the probable causes:

Pump will not start

1. No power to the motor. Check for blown fuse or open circuit.
2. Selector switch may be in the Off position.
3. Control circuit transformer fuse may be blown.
4. Overload heater on starter may be tripped. Push to reset.

Pump will not start and overload heaters trip

1. Turn off power and check motor leads with Megger or ohmmeter for possible ground.

2. Check resistance of motor windings. All 3 phases should show the same reading.
3. If no grounds exist and the motor windings check OK, remove discharge elbow cover and check for clogged or blocked impeller.

Pump operates with selector switch in Hand position but will not operate in Auto position

1. This indicates trouble in the float level control or alternator relay.
2. Check control panel for trouble.

Pump runs but will not shut off

1. Pump may be air locked. Turn pump off and let set for several minutes, then restart.
2. Lower float control may be hung up in the closed position. Check in wet well to be sure the control is free.
3. Selector switch may be in the Hand position.

Pump does not deliver proper capacity

1. Discharge gate valve may be partially closed or partially clogged.
2. Check valve may be partially clogged. Raise lever up and down to clear.
3. Pump may be running in the wrong direction. Low speed pumps can operate in reverse direction without much noise or vibration.
4. Discharge head may be too high. Check total head with gauge when pump is operating.
5. If pump has been in service for some time and capacity falls off, remove pump and inspect impeller for wear.

Motor stops and then restarts after short period but overload heaters in starter do not trip

1. This indicates heat sensors in the motor are tripping due to excessive heat. Impeller may be partially clogged giving sustained overload but not high enough to trip overload heaters.
2. Pump may be operating on a short cycle due to faulty check valve in the wet well.

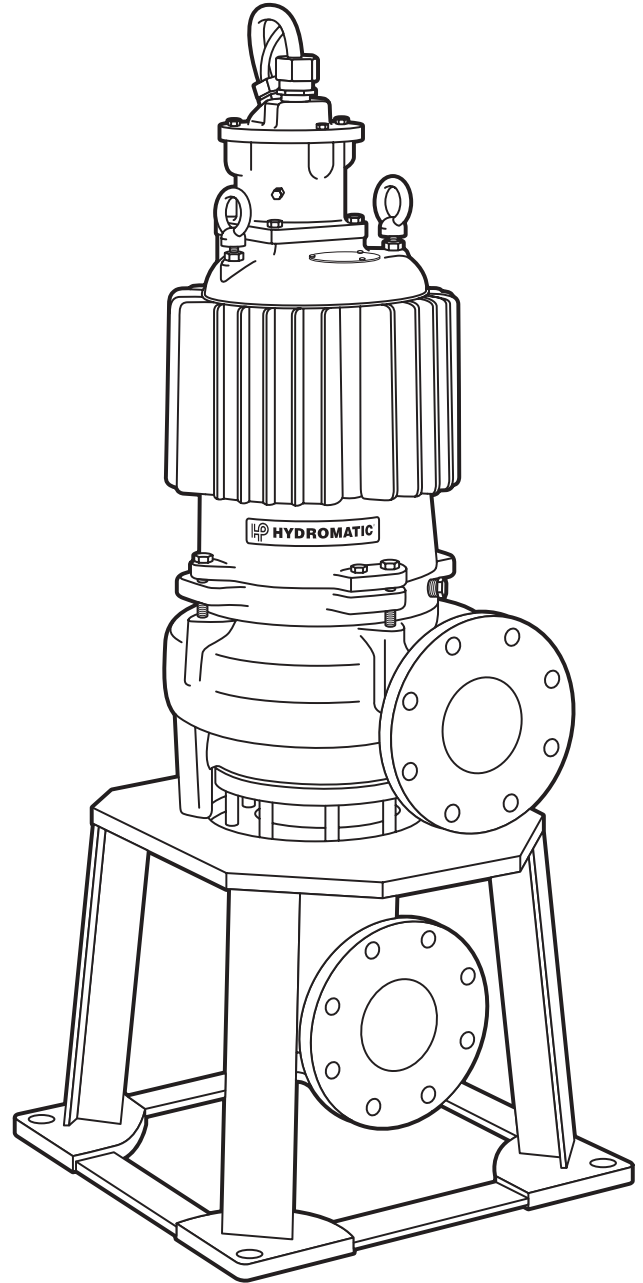
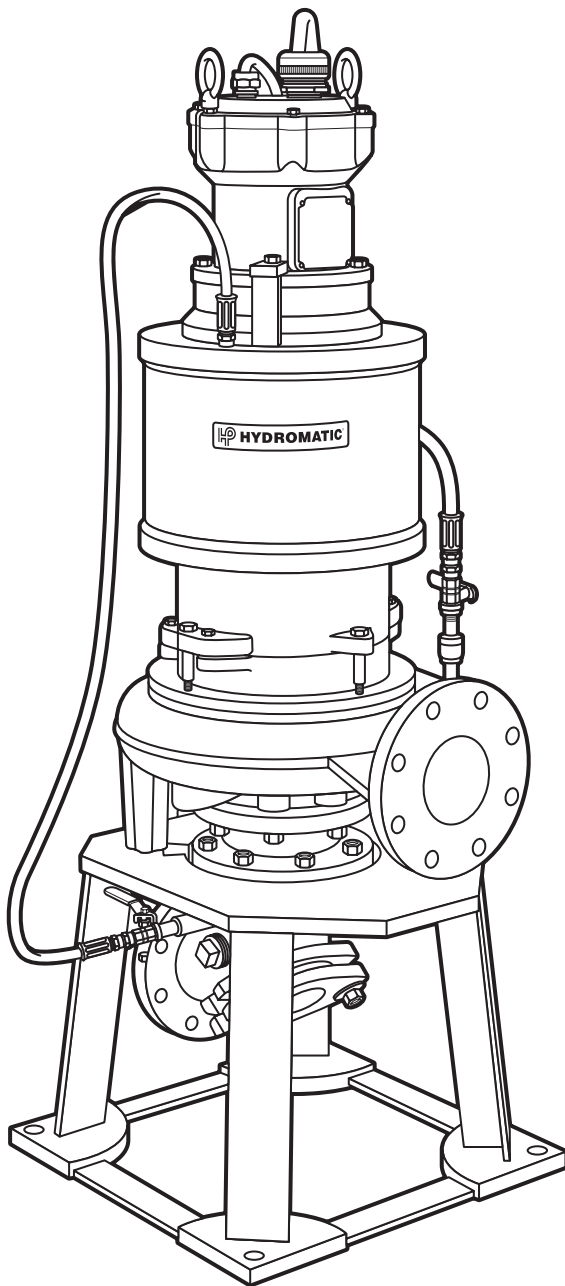

WARRANTY

Hydromatic® warrants to the original purchaser of each Hydromatic product(s) that any part thereof that proves to be defective in material or workmanship within one year from date of installation or 18 months from manufacture date, whichever comes first, will be replaced at no charge with a new or remanufactured part, F.O.B. factory. Purchaser shall assume all responsibility and expense from removal, reinstallation and freight. Any item(s) designated as manufactured by others shall be covered only by the express warranty of the manufacturer thereof. This warranty does not apply to damage resulting from accident, alteration, design, misuse or abuse. The pump must be installed, operated and maintained in accordance with the published instructions of the appropriate Installation & Service Manual.

All dual seal non-clogs and 3–5 HP grinders must have seal failure and heat sensors attached and functional for Warranty to be in effect. If a seal failure should occur, Hydromatic will cover only the lower seal and labor thereof. Labor is based on Authorized Service Center contract allowance. If the heat sensor is not attached and functional, Warranty is void. If the seal failure sensor is not attached and functional, Warranty is void.

If the material furnished to the Buyer shall fail to conform to this contract or to any of the terms of this written warranty, Hydromatic shall replace such nonconforming material at the original point of delivery and shall furnish instruction for its disposition. Any transportation charges involved in such disposition shall be for the Buyer's account. The Buyer's exclusive and sole remedy on account or in respect of the furnishing of material that does not conform to this contract or to this written warranty, shall be to secure replacement thereof as aforesaid. Hydromatic shall not in any event be liable for the cost of any labor expended on any such material or for any incidental or consequential damages to anyone by reason of the fact that such material does not conform to this contract or to this written warranty.

ALL IMPLIED WARRANTIES, INCLUDING THE IMPLIED WARRANTY OF MERCHANTABILITY AND THE IMPLIED WARRANTY OF FITNESS FOR A PARTICULAR PURPOSE, ARE DISCLAIMED TO THE SAME EXTENT AS THE EXPRESS WARRANTY CONTAINED HEREIN. Some states do not allow limitations on how long an implied warranty lasts, so the above limitation may not apply to you.

MANUFACTURER EXPRESSLY DISCLAIMS AND EXCLUDES ANY LIABILITY FOR CONSEQUENTIAL OR INCIDENTAL DAMAGES FOR BREACH OF ANY EXPRESS OR IMPLIED WARRANTY ARISING IN CONNECTION WITH THIS PRODUCT, INCLUDING WITHOUT LIMITATION, WHETHER IN TORT, NEGLIGENCE, STRICT LIABILITY CONTRACT OR OTHERWISE. Some states do not allow the exclusion or limitation of incidental or consequential damages, so the above limitation or exclusion may not apply to you. This warranty gives you specific legal rights, and you may also have other rights which vary from state to state.



HYDROMATIC®

Pentair Water

USA

740 East 9th Street, Ashland, Ohio 44805
Tel: 419-289-3042 Fax: 419-281-4087

www.hydromatic.com

– Your Authorized Local Distributor –

CANADA

269 Trillium Drive, Kitchener, Ontario, Canada N2G 4W5
Tel: 519-896-2163 Fax: 519-896-6337