



HYDROMATIC®

118 SYSTEM

Sump Pump Hide-Away Basin Package

V-A1/118 Hide-Away System Includes:

- V-A1, 115V Automatic Submersible Sump Pump
- Polyethylene water box with cover, schedule 40 PVC nipple and swing check valve



Piggyback Switch Plug

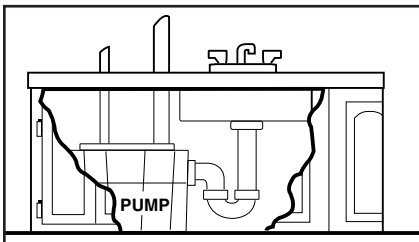
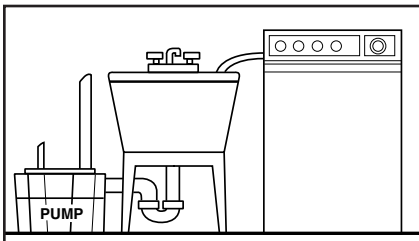
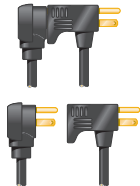

Pentair
Water™

118 System - Sump Pump Hide-Away Basin Package

Details

The Hydromatic 118 Basin System is here for the professional plumber. This package is an economical, above floor system. The Hydromatic 118 Basin System allows you to add a drain without adding the headache of major remodeling (i.e. cutting concrete to install a basin). The 118 Basin System is a solution for immediate installation as well as a great idea for retro-fitting. The compact polyethylene water box with outside dimensions of approximately 17" x 12" x 14" (see dimensional drawing) is ideal for small places. Although compact, it has the capacity for washing machine discharge, laundry trays, utility sinks, wet bars and air conditioning or dehumidifier drainage.

At the heart of the Hydromatic 118 Basin System is the V-A1 sump pump. This .3 HP heavy-duty sump pump is a proven Hydromatic design that runs on 115 volts. The oil-cooled motor also has built-in automatic thermal overload protection and a 10' power cord. The compact basin & V-A1 pump make the Hydromatic 118 Basin System a value-packed package for the professional plumber.

Pump Characteristics

Pump/Motor Unit	Submersible
Automatic Models	V-A1
Horsepower	.3
Full Load Amps	8.0
Motor Type	Shaded Pole (4 pole)
R.P.M.	1550
Phase Ø	1
Voltage	115
Hertz	60
Temperature	120°F Ambient
NEMA Design	A
Insulation	Class A
Discharge Size	1-1/2" NPT (38mm)
Solids Handling	1/2" (13mm)
Unit Weight	30 lbs.
Power Cord	18/3, SJTW, 10' std.

Performance Data

Total Head (feet)	5	10	15	20	25
GPM (U.S.)	46	38	30	18	0

Dimensional Data

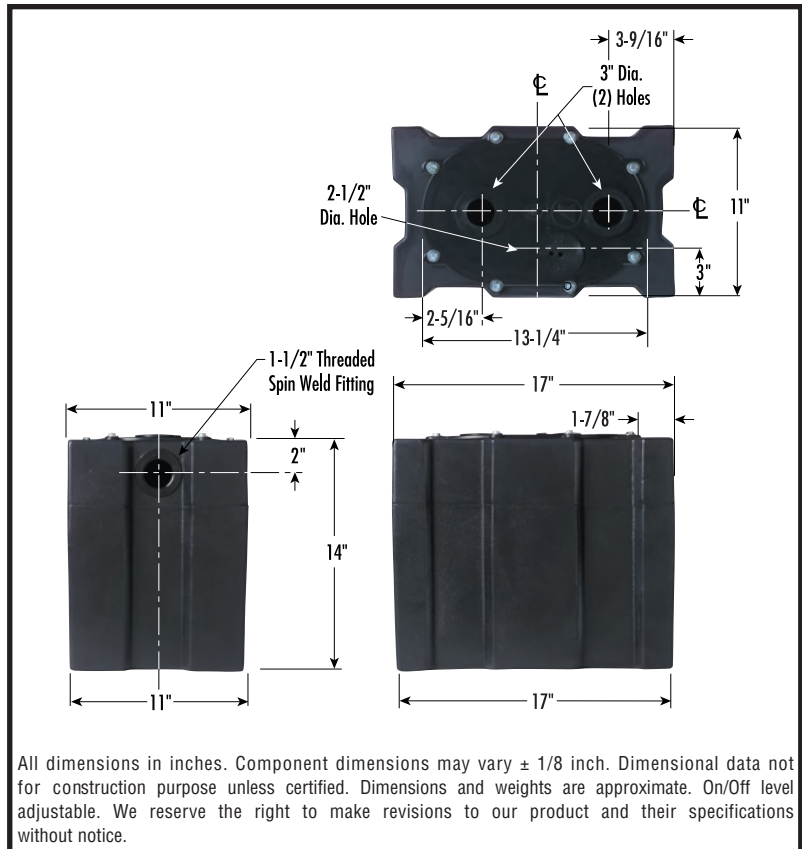

Materials of Construction

Handle	Stainless Steel
Lubricating Oil	Dielectric Oil
Motor Housing	Cast Iron
Pump Casing	Cast Iron
Shaft	Steel
Mechanical Shaft Seal	Seal Faces: Carbon/Ceramic Seal Body: Anodized Steel Spring: Stainless Steel Bellows: Buna-N
Impeller	Thermoplastic
Upper Bearing	Cast Iron Sleeve
Lower Bearing	Ball Bearing
Strainer/Base	Plastic
Fasteners	Stainless Steel



- Your Authorized Local Distributor -

USA

740 East 9th Street Ashland, Ohio 44805
Tel: 419-289-3042 Fax: 419-281-4087

www.hydromatic.com

CANADA

269 Trillium Drive Kitchener, Ontario, Canada N2G 4W5
Tel: 519-896-2163 Fax: 519-896-6337