

## HBB-SKV40 4/10 HP BASIN BOSS™ PACKAGED SEWAGE SYSTEM

### 24" x 24" Basin

30% more capacity than standard 18" x 30" basins.

### Fully Assembled

Pump is pre-installed in basin, with integral torque stops to ensure stability.

### Anti-Flotation Features

Include concrete splash lip and unique basin shape to keep the system from floating or becoming "un-installed".

### Integral 360° Top Grip

For easy lifting and handling in tight spaces.

### Stackable Design

Allows for compact inventory.

### Concrete-Proof Cover Insert

Protects the system from damage during rough-in and masonry work.

### Easy-Out™ Rod

Allows removal of float switch without disassembling basin lid, or handling pump or plumbing. Additional clip for secondary float included; float sold separately.

### Available with Q-Alert™ High-Water Alarm

Small, residential high-water alarm is ideal for furnishing an inexpensive way to protect home and valuables. Indoor/outdoor applications, sold separately.



Catalog Number	HP	Package Type	Cord Length	Switch Type	Basin Size	Includes Alarm
HBB-SKV40	4/10	Preassembled	10'	Wide-angle float switch	24" x 24"	No
HBB-SKV40-QAlert	4/10	Preassembled	10'	Wide-angle float switch	24" x 24"	Yes

# SKV40 4/10 HP Basin Boss™ Packaged Sewage System

## Details

### Pump Characteristics

Pump/Motor Unit	Submersible	
Automatic Models	SKV40A1	SKV40A2
Horsepower	4/10	
Full Load Amps	12.6	6.4
Motor Type	Split Phase	
RPM	1550	
Phase Ø	1	
Voltage	115	230
Hertz	60	
Operation	Intermittent	
Temperature	120°F Ambient	
NEMA Design	A	
Insulation	Class B	
Discharge Size	2" NPT std.	
Solids Handling	2"	
Unit Weight	35 lbs.	
Power Cord	18/3, SJTW, 115V = 10' std. (20' opt.)	

### Performance Data

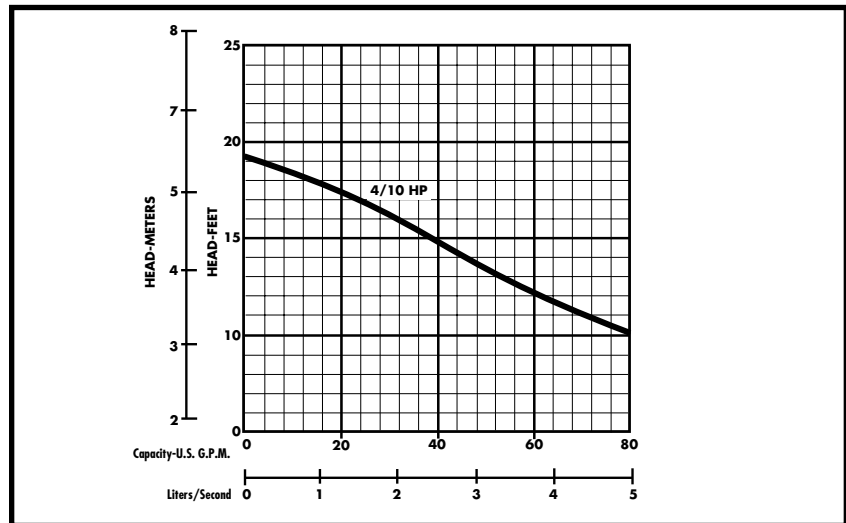

### Specifications

#### Pump

- Housing – Class 30 cast iron
- Impeller – Thermoplastic recessed
- Maximum Limits – Intermittent liquid temperature: 120°F (60°C)
- Electrical – 115V, 1Ø, 12.6 FLA, 60 Hz  
230V, 1Ø, 6.4 FLA, 60 Hz
- Motor – 4/10 HP split phase w/thermal overload protection, 1550 RPM

#### Basin

- Construction – Structural foam;  
24" x 24"; 45-gallon capacity

### Dimensional Data

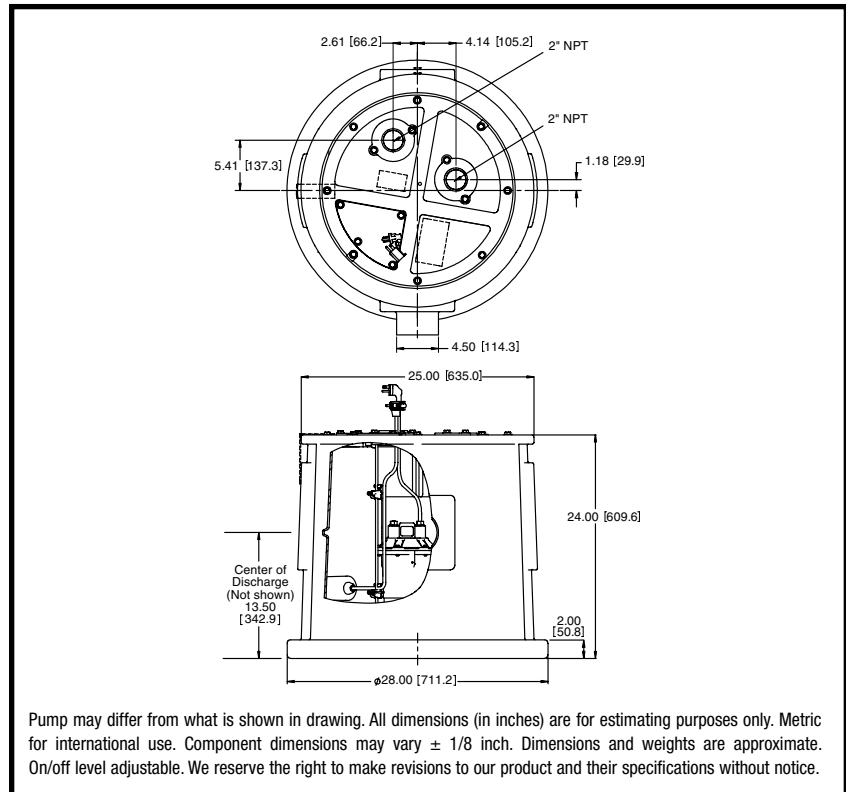

- Your Authorized Local Distributor -

**HYDROMATIC®**  
Pentair Water

USA

740 East 9th Street, Ashland, Ohio 44805  
Tel: 1-888-957-8677 Fax: 419-281-4087

www.hydomatic.com

CANADA

269 Trillium Drive, Kitchener, Ontario, Canada N2G 4W5  
Tel: 519-896-2163 Fax: 519-896-6337