



HYDROMATIC®

HC20

Condensate Unit



The Hydromatic HC20 Condensate unit is designed to automatically remove the liquid from an air conditioner evaporative coil and/or a gas condensing warm air furnace. This unit is made from a tough ABS plastic so it will resist corrosion and impacts.



Pentair
Water™

HC20 - Condensate Unit

Details

Pump Characteristics

Pump/Motor Unit	Condensate Unit
Capacities	95 GPH
Heads	20 ft.
Liquids	Drain Water
Tank Capacities	2.0 Quarts
Temperature	190° F
Motor Type	Electrical
Full Load Amps	1.45
Voltage	115
Hertz	60
Unit Weight	3.25 lbs.
Dimensions	11" x 5" x 4-3/4"
Housing	Thermoplastic
Power Cord Size	6'

Performance Chart

HEAD-FEET	FLows (GPH)
1	95
5	85
10	70
15	45
20	0

Items Included

- UL & cUL Listed Condensate Unit with 6' power cord.
- Check Valve to prevent backflow of liquid into the unit.
- Overflow Safety Switch.
- Instruction Manual.

Condensate Unit



Dimensional Data

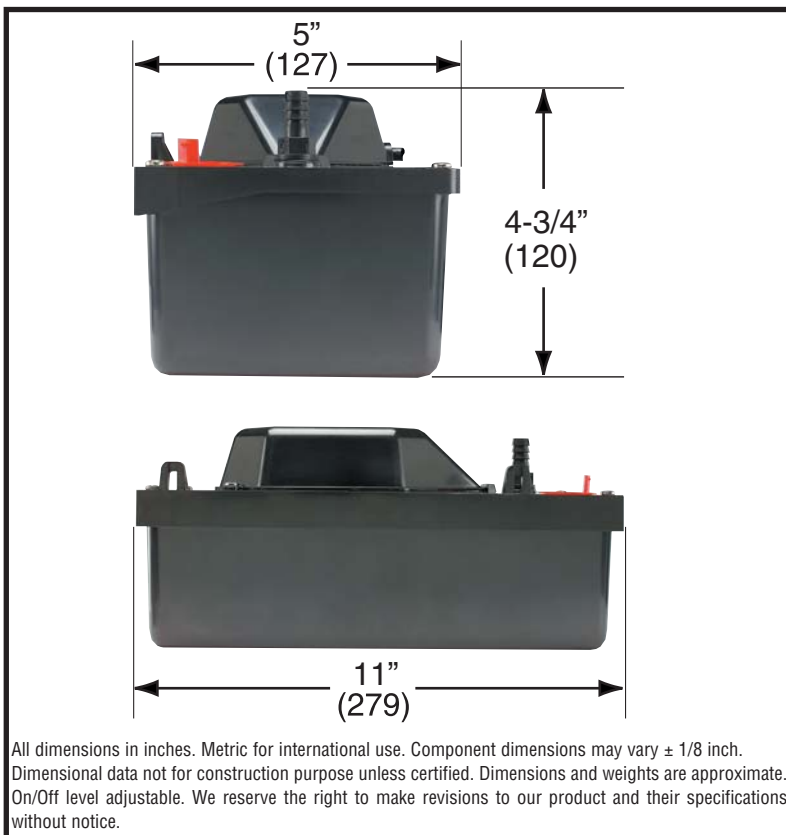

— Your Authorized Local Distributor —

USA
740 East 9th Street Ashland, Ohio 44805
Tel: 419-289-3042 Fax: 419-281-4087

www.hydromatic.com

CANADA
269 Trillium Drive Kitchener, Ontario, Canada N2G 4W5
Tel: 519-896-2163 Fax: 519-896-6337